

# Short-stroke cylinder, Series KHZ

- Ø 8-100 mm
- Ports M5, G 1/8, G 1/4
- Single-acting, retracted without pressure
- Cushioning elastic
- Piston rod Internal thread

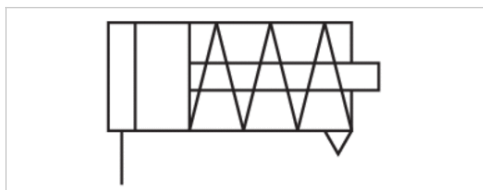

Compressed air connection	Internal thread
Ambient temperature min./max.	-25 ... 80 °C
Medium temperature min./max.	-25 ... 80 °C
Medium	Compressed air
Max. particle size	50 µm
Oil content of compressed air	0 ... 5 mg/m <sup>3</sup>
Pressure for determining piston forces	6.3 bar
Weight	See table below



## Technical data

Piston Ø Piston rod thread Ports	8 mm M5	12 mm M5	16 mm M5 M5	20 mm M5 M5	25 mm M5 G 1/8	32 mm M6 G 1/8
Stroke 4	0822406001	0822406020	0822406310	0822406320	-	-
5	-	-	-	-	0822406330	0822406340
10	-	0822406021	0822406311	0822406321	0822406331	0822406341
25	-	-	0822406312	0822406322	0822406332	0822406342

Piston Ø Piston rod thread Ports	40 mm M6 G 1/8	50 mm M8 G 1/8	63 mm M8 G 1/8	80 mm M10 G 1/4	100 mm M12 G 1/4
Stroke 4	-	-	-	-	-
5	0822406350	-	-	-	-
10	0822406351	0822406361	0822406371	-	-
25	0822406352	0822406362	0822406372	R402005783	R402005840

Other versions can be ordered from AVENTICS sales offices., For 0822406310 piston material: Polyurethane

## Technical data

Piston Ø	8 mm	12 mm	16 mm	20 mm
Retracting piston force	2,8 N	6,8 N	8 N	6,5 N
Extracting piston force	32 N	71 N	127 N	198 N
Working pressure min./max.	2 ... 10 bar	1,7 ... 10 bar	1,5 ... 10 bar	1,5 ... 10 bar
Material, front cover	Brass	Brass	Brass	Brass

Piston Ø	25 mm	32 mm	40 mm	50 mm
Retracting piston force	15,5 N	18,5 N	26 N	39 N
Extracting piston force	309 N	507 N	792 N	1237 N
Working pressure min./max.	1,5 ... 10 bar	1,3 ... 10 bar	1,3 ... 10 bar	1 ... 10 bar
Material, front cover	Brass	Aluminum	Aluminum	Aluminum

Piston Ø	63 mm	80 mm	100 mm
Retracting piston force	48 N	54 N	95 N
Extracting piston force	1964 N	3167 N	4948 N
Working pressure min./max.	1 ... 10 bar	1 ... 10 bar	1 ... 10 bar
Material, front cover	Aluminum	Aluminum	Aluminum

## Technical information

The pressure dew point must be at least 15 °C under ambient and medium temperature and may not exceed 3 °C .

The oil content of compressed air must remain constant during the life cycle.

Use only the approved oils from AVENTICS. Further information can be found in the "Technical information" document (available in the MediaCentre).

## Technical information

Material	
Cylinder tube	Aluminum, anodized
Piston rod	Stainless steel
Piston	Nitrile rubber
Front cover	Brass, Aluminum
End cover	Aluminum

# Dimensions

## Dimensions

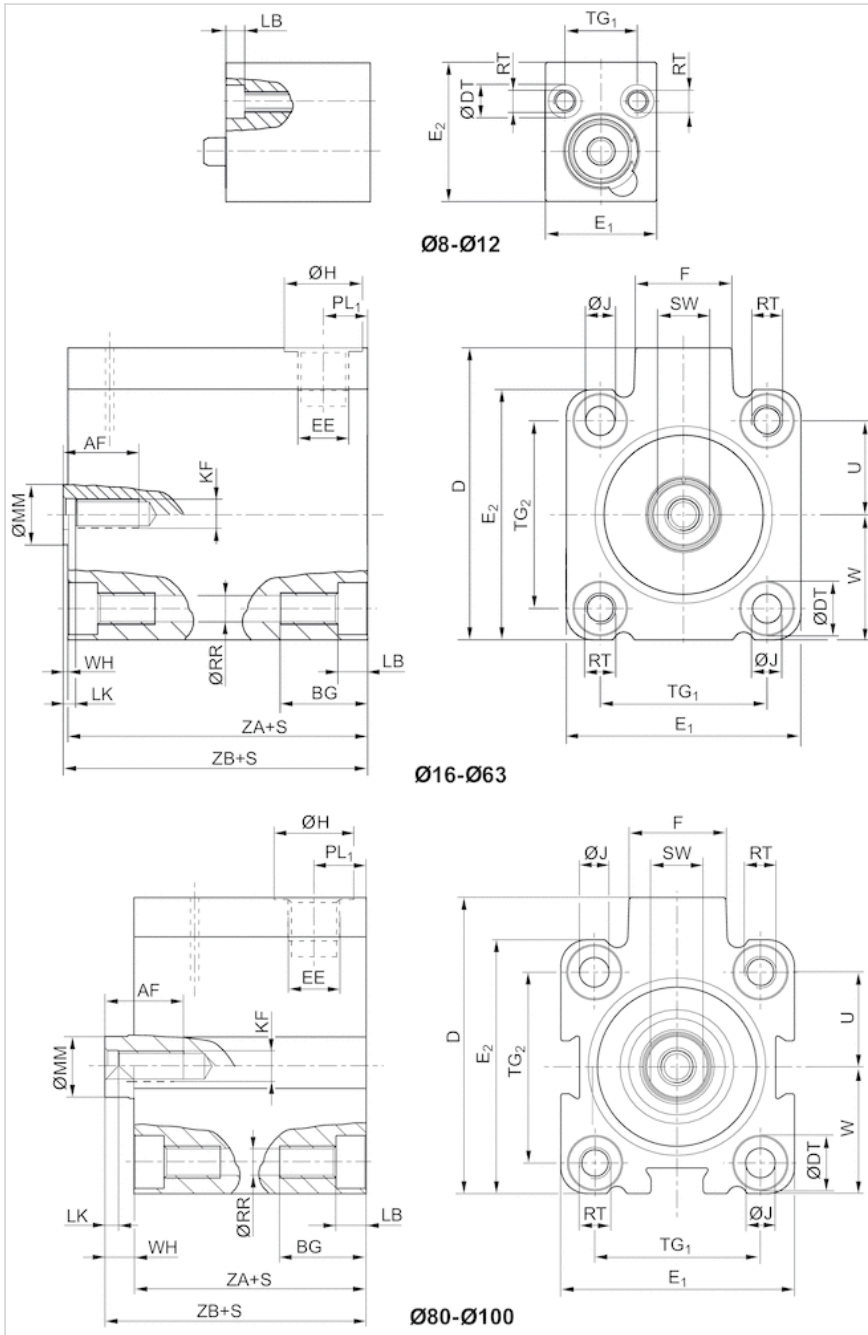

S = stroke

## Dimensions

Piston Ø	S	AF+1	BG 1)	DJS15	ØDTH13	E1JS15	E2JS15	EE	F	ØH	ØJH14	KF	LB+0,4
8 mm	4	-	8	-	6	18	20	M5	-	8	-	-	3.4
12 mm	4 - 10	-	8	-	6	20	25	M5	-	8	-	-	3.4
12 mm	-	-	-	-	-	-	-	-	-	-	-	-	-
16 mm	4 - 10	10	12.4	33	6	28	28	M5	11.5	8	3.55	M5	3.4
16 mm	-	-	-	-	-	-	-	-	-	-	-	-	-
16 mm	25	10	17.5	33	6	28	28	M5	11.5	8	3.55	M5	8.5
20 mm	4	9	13.6	37	7.5	32	32	M5	11	8	4.55	M5	4.6
20 mm	10 - 25	10	13.6	37	7.5	32	32	M5	11	8	4.55	M5	4.6
20 mm	-	-	-	-	-	-	-	-	-	-	-	-	-
25 mm	5 - 25	10	13.6	47.5	8	37	39	G1/8	17.5	15	4.55	M5	4.6
25 mm	-	-	-	-	-	-	-	-	-	-	-	-	-
32 mm	5 - 25	14.5	16.7	56	10	45	48	G1/8	18.5	15	5.5	M6	5.7
32 mm	-	-	-	-	-	-	-	-	-	-	-	-	-
40 mm	5	13	16.7	62.5	10	54.5	54.5	G1/8	18.5	15	5.5	M6	5.7
40 mm	10 - 25	14.5	16.7	62.5	10	54.5	54.5	G1/8	18.5	15	5.5	M6	5.7
40 mm	-	-	-	-	-	-	-	-	-	-	-	-	-
50 mm	10 - 25	15.5	19.8	72	11	64	64	G1/8	18	15	7.3	M8	6.8
50 mm	-	-	-	-	-	-	-	-	-	-	-	-	-
63 mm	10 - 25	18	25	88	15	80	80	G1/8	23	15	9.2	M8	9
63 mm	-	-	-	-	-	-	-	-	-	-	-	-	-
80 mm	25	18	25	110	15	100	100	G1/4	27	19	9.2	M10	9
100 mm	25	20	30	132	17.5	124	124	G1/4	28	19	11	M12	11

Piston Ø	LK+0,5	ØMMf8	PL1	ØRR	RT	SW-0,3	TG1	TG2	U	W	WH	ZA±0,2
8 mm	-	4	5	3.3	M4	-	11 ±0,2	-	8	6,5 ±0,2	1	12
12 mm	-	5	5	3.3	M4	-	13 ±0,2	-	9	9 ±0,2	1	12
12 mm	-	-	-	-	-	-	-	-	-	-	-	-
16 mm	2	8	5	3.3	M4	7	20 ±0,2	20 ±0,2	10	14 ±0,2	1	20
16 mm	-	-	-	-	-	-	-	-	-	-	-	-
16 mm	2	8	5	3.3	M4	7	20 ±0,2	20 ±0,2	10	14 ±0,2	1	28
20 mm	2	10	5	4.2	M5	8	22 ±0,2	22 ±0,2	11	16 ±0,2	1	16
20 mm	2	10	5	4.2	M5	8	22 ±0,2	22 ±0,2	11	16 ±0,2	1	22
20 mm	-	-	-	-	-	-	-	-	-	-	-	-
25 mm	2	10	8.5	4.2	M5	8	26 ±0,25	28 ±0,25	14	19,5 ±0,2	1	21
25 mm	-	-	-	-	-	-	-	-	-	-	-	-
32 mm	2.5	12	8.5	5.05	M6	10	32 ±0,25	36 ±0,25	18	24 ±0,2	1	21
32 mm	-	-	-	-	-	-	-	-	-	-	-	-
40 mm	2.5	12	8.5	5.05	M6	10	40 ±0,25	40 ±0,25	20	27,3 ±0,2	1	21
40 mm	2.5	12	8.5	5.05	M6	10	40 ±0,25	40 ±0,25	20	27,3 ±0,2	1	21
40 mm	-	-	-	-	-	-	-	-	-	-	-	-
50 mm	3.5	16	8.5	6.8	M8	13	50 ±0,25	50 ±0,25	25	32 ±0,2	1	20
50 mm	-	-	-	-	-	-	-	-	-	-	-	-
63 mm	3.5	16	8.5	8.5	M10	13	62 ±0,25	62 ±0,25	31	40 ±0,2	1	25
63 mm	-	-	-	-	-	-	-	-	-	-	-	-
80 mm	4	20	12	8.5	M10	17	82 ±0,3	82 ±0,3	41	50 ±0,3	1	42
100 mm	4	25	12	10.2	M12	22	103 ±0,3	103 ±0,3	51.5	62 ±0,3	1	49.5

Piston Ø	ZB±0,8
8 mm	13
12 mm	13
12 mm	-
16 mm	21
16 mm	-
16 mm	29
20 mm	17
20 mm	23
20 mm	-
25 mm	22
25 mm	-
32 mm	22
32 mm	-
40 mm	22
40 mm	22
40 mm	-
50 mm	21
50 mm	-
63 mm	26
63 mm	-
80 mm	43
100 mm	50.5

1) Min.

S = stroke

## Weight [kg]

Piston Ø	S	Weight kg
8 mm	4	0,017 kg
12 mm	4	0,024 kg
12 mm	10	0,034 kg
16 mm	4	0,057 kg
16 mm	10	0,075 kg
16 mm	25	0,114 kg
20 mm	4	0,061 kg
20 mm	10	0,09 kg
20 mm	25	0,147 kg
25 mm	5	0,11 kg
25 mm	10	0,132 kg
25 mm	25	0,218 kg
32 mm	5	0,135 kg
32 mm	10	0,163 kg
32 mm	25	0,296 kg
40 mm	5	0,225 kg
40 mm	10	0,21 kg
40 mm	25	0,378 kg
50 mm	10	0,268 kg
50 mm	25	0,492 kg

Piston Ø	S	Weight kg
63 mm	10	0,458 kg
63 mm	25	0,75 kg
80 mm	25	1,29 kg
100 mm	25	2,3 kg

S = stroke

## Accessories overview

### Overview drawing

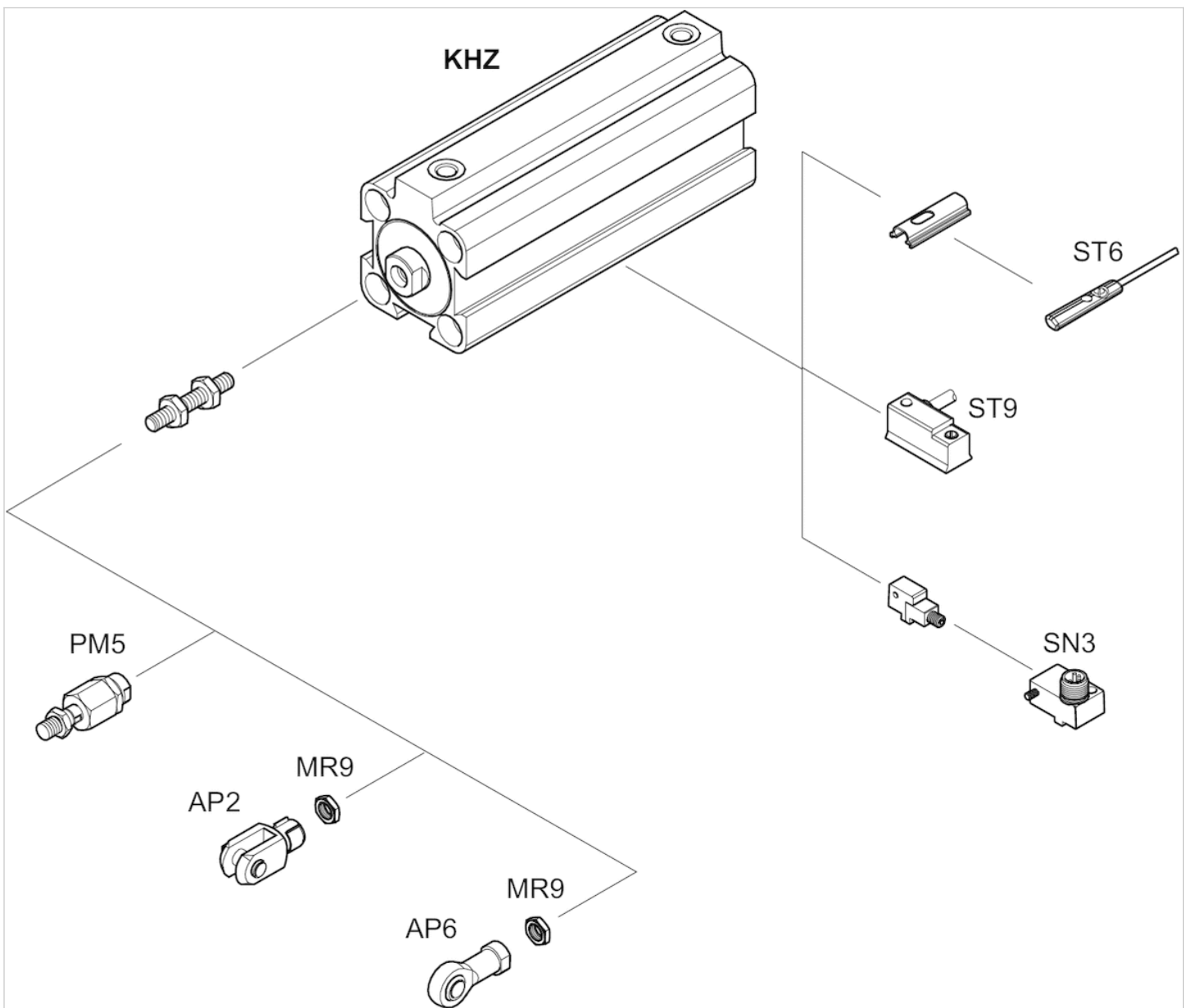

NOTE: This overview drawing is only for orientation to indicate where the various accessory parts can be fastened to the cylinder. The illustration has been simplified for this purpose. It is thus not possible to derive the dimensions from this overview.

# Short-stroke cylinder, Series KHZ

- Ø 12-100 mm
- Ports M5, G 1/8, G 1/4
- Single-acting, retracted without pressure
- with magnetic piston
- Cushioning elastic
- Piston rod Internal thread



Compressed air connection	Internal thread
Ambient temperature min./max.	-25 ... 80 °C
Medium temperature min./max.	-25 ... 80 °C
Medium	Compressed air
Max. particle size	50 µm
Oil content of compressed air	0 ... 5 mg/m <sup>3</sup>
Pressure for determining piston forces	6.3 bar
Weight	See table below

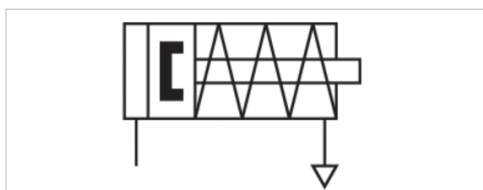

## Technical data

Piston Ø Piston rod thread Ports	12 mm M3 M5	16 mm M5 M5	20 mm M5 M5	25 mm M5 G 1/8	32 mm M6 G 1/8	40 mm M6 G 1/8
Stroke 4	0822406400	0822406410	0822406420	-	-	-
5	-	-	-	0822406430	0822406440	0822406450
10	0822406401	0822406411	0822406421	0822406431	0822406441	0822406451
25	-	0822406412	0822406422	0822406432	0822406442	0822406452

Piston Ø Piston rod thread Ports	50 mm M8 G 1/8	63 mm M8 G 1/8	80 mm M10 G 1/4	100 mm M12 G 1/4
Stroke 4	-	-	-	-
5	-	-	-	-
10	0822406461	0822406471	0822406481	0822406491
25	0822406462	0822406472	0822406482	0822406492

Other versions can be ordered from AVENTICS sales offices.

## Technical data

Piston Ø	12 mm	16 mm	20 mm	25 mm
Retracting piston force	6,8 N	8 N	6,5 N	15,5 N
Extracting piston force	71 N	127 N	198 N	309 N
Working pressure min./max.	1,7 ... 10 bar	1,5 ... 10 bar	1,5 ... 10 bar	1,5 ... 10 bar
Material, front cover	Brass	Brass	Brass	Brass

Piston Ø	32 mm	40 mm	50 mm	63 mm
Retracting piston force	18,5 N	26 N	39 N	48 N
Extracting piston force	507 N	792 N	1237 N	1964 N
Working pressure min./max.	1,3 ... 10 bar	1,3 ... 10 bar	1 ... 10 bar	1 ... 10 bar
Material, front cover	Aluminum	Aluminum	Aluminum	Aluminum

Piston Ø	80 mm	100 mm
Retracting piston force	63,5 N	95,5 N
Extracting piston force	3267 N	4948 N
Working pressure min./max.	1 ... 10 bar	1 ... 10 bar
Material, front cover	Aluminum	Aluminum

## Technical information

The pressure dew point must be at least 15 °C under ambient and medium temperature and may not exceed 3 °C .

The oil content of compressed air must remain constant during the life cycle.

Use only the approved oils from AVENTICS. Further information can be found in the "Technical information" document (available in the MediaCentre).

## Technical information

Material	
Cylinder tube	Aluminum, anodized
Piston rod	Stainless steel
Piston	Nitrile rubber
Front cover	Brass, Aluminum
End cover	Aluminum

# Dimensions

## Dimensions

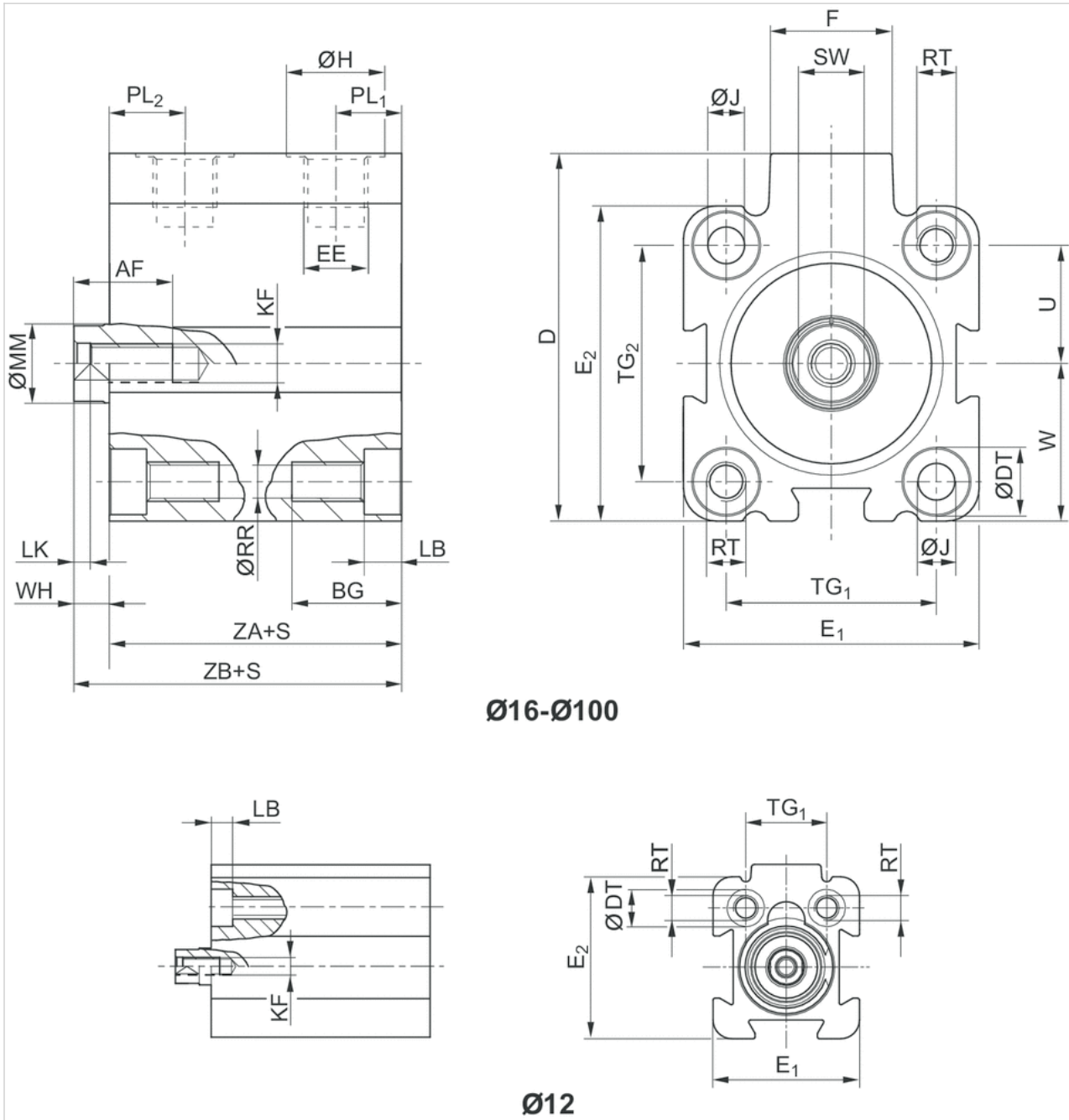

**Ø16-Ø100**

**Ø12**

S = stroke

## Dimensions

Piston Ø	S	AF+1	BG 1)	DJS15	ØDTH13	E1JS15	E2JS15	EE	F	ØH	ØJH14	KF
12 mm	4 - 10	8	12.4	28	6	23.5	26	M 5	11	8	-	M 3
12 mm	-	-	-	-	-	-	-	-	-	-	-	-
16 mm	4 - 25	10	12.4	33	6	28	28	M 5	11.5	8	3.55	M 5
16 mm	-	-	-	-	-	-	-	-	-	-	-	-
20 mm	4 - 25	10	13.6	37	7.5	32	32	M 5	11	8	4.55	M 5
20 mm	-	-	-	-	-	-	-	-	-	-	-	-
25 mm	5 - 25	10	13.6	47.5	8	37	39	G 1/8	17.5	15	4.55	M 5
32 mm	5 - 25	15	16.7	56	10	45	48	G 1/8	18.5	15	5.5	M 6
40 mm	5 - 25	15	16.7	62.5	10	54.5	54.5	G 1/8	18.5	15	5.5	M 6
50 mm	10 - 25	18	19.8	73	11	66	66	G 1/8	18	15	7.3	M 8
63 mm	10 - 25	18	25	88	15	80	80	G 1/8	23	15	9.2	M 8
80 mm	10 - 25	18	25	110	15	100	100	G 1/4	27	19	9.2	M 10
100 mm	10 - 25	20	30	132	17.5	124	124	G 1/4	28	19	11	M 12

Piston Ø	LB+0,4	LK+0,5	ØMMf8	PL1	PL2	ØRR	RT	SW-0,3	TG1	TG2±0,2	U	W
12 mm	3.4	2	6	6	10.5	3.3	M 4	5	13 ±0,2	-	9.5	11,5 ±0,2
12 mm	-	-	-	-	-	-	-	-	-	-	-	-
16 mm	3.4	2	8	6.5	12.5	3.3	M 4	7	20 ±0,2	20 ±0,2	10	14 ±0,2
16 mm	-	-	-	-	-	-	-	-	-	-	-	-
20 mm	4.6	2	10	6.5	12	4.2	M 5	8	22 ±0,2	22 ±0,2	11	16 ±0,2
20 mm	-	-	-	-	-	-	-	-	-	-	-	-
25 mm	4.6	2	10	9.5	11.5	4.2	M 5	8	26 ±0,25	28 ±0,25	14	19,5 ±0,2
32 mm	5.7	2.5	12	10	11.5	5.05	M 6	10	32 ±0,25	36 ±0,25	18	24 ±0,2
40 mm	5.7	2.5	12	10	13.5	5.05	M 6	10	40 ±0,25	40 ±0,25	20	27,3 ±0,2
50 mm	6.8	3.5	16	10	14	6.8	M 8	13	50 ±0,25	50 ±0,25	25	33 ±0,2
63 mm	9	3.5	16	11.5	14	8.5	M 10	13	62 ±0,25	62 ±0,25	31	40 ±0,2
80 mm	9	4	20	12	18	8.5	M 10	17	82 ±0,3	82 ±0,3	41	50 ±0,3
100 mm	11	4	25	12	20.5	10.2	M 12	22	103 ±0,3	103 ±0,3	51.5	62 ±0,3

Piston Ø	WH	ZA±0,2	ZB±0,8
12 mm	4.5	30.5	35
12 mm	-	-	-
16 mm	3	32	35
16 mm	-	-	-
20 mm	4.5	32	36.5
20 mm	-	-	-
25 mm	5	39	44
32 mm	5.5	39.5	45
40 mm	7	39.5	46.5
50 mm	7.5	39.5	47
63 mm	6.5	42	48.5
80 mm	8	46	54
100 mm	10	56	66

1) Min.

S = stroke

## Weight [kg]

Piston Ø	S	Weight kg
12 mm	4	0,051 kg
16 mm	10	0,075 kg
16 mm	25	0,085 kg
20 mm	4	0,095 kg
20 mm	10	0,095 kg
20 mm	25	0,105 kg
25 mm	5	0,175 kg
25 mm	10	0,175 kg
25 mm	25	0,175 kg
32 mm	5	0,226 kg
32 mm	10	0,226 kg
32 mm	25	0,226 kg
40 mm	5	0,318 kg
40 mm	10	0,318 kg
40 mm	25	0,318 kg
50 mm	10	0,49 kg
50 mm	25	0,49 kg
63 mm	10	0,732 kg
63 mm	25	0,732 kg
80 mm	10	1,29 kg
80 mm	25	1,29 kg
100 mm	10	2,3 kg
100 mm	25	2,3 kg

S = stroke

## Accessories overview

### Overview drawing

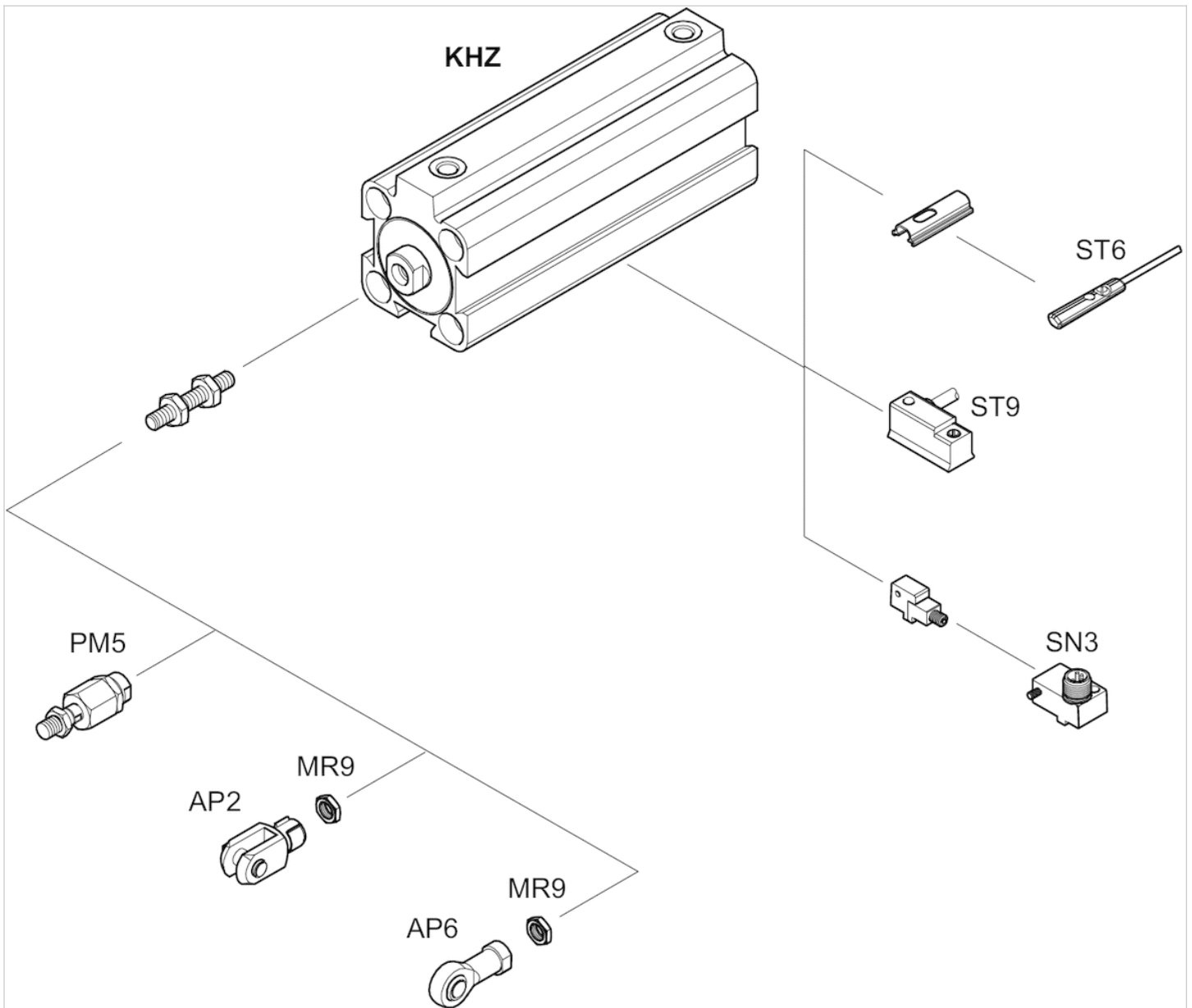

NOTE: This overview drawing is only for orientation to indicate where the various accessory parts can be fastened to the cylinder. The illustration has been simplified for this purpose. It is thus not possible to derive the dimensions from this overview.

# Short-stroke cylinder, Series KHZ

- Ø 12-100 mm
- Ports M5, G 1/8, G 1/4
- double-acting
- Cushioning elastic
- Piston rod External thread, Internal thread



Ambient temperature min./max.	-25 ... 80 °C
Medium temperature min./max.	-25 ... 80 °C
Medium	Compressed air
Max. particle size	50 µm
Oil content of compressed air	0 ... 5 mg/m <sup>3</sup>
Pressure for determining piston forces	6.3 bar

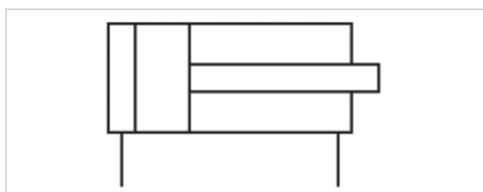

## Technical data

Piston Ø Piston rod thread Ports	12 mm M5 M5	16 mm M5 M5	20 mm M5 M5	25 mm M5 G 1/8	32 mm M6 G 1/8	40 mm M6 G 1/8
Stroke 5	0822010500	0822010510	0822010520	0822010530	0822010540	0822010550
10	0822010501	0822010511	0822010521	0822010531	0822010541	0822010551
15	0822010502	0822010512	0822010522	0822010532	0822010542	0822010552
20	0822010503	0822010513	0822010523	0822010533	0822010543	0822010553
25	0822010504	0822010514	0822010524	0822010534	0822010544	0822010554
30	0822010505	0822010515	0822010525	0822010535	0822010545	0822010555
40	0822010506	0822010516	0822010526	0822010536	0822010546	0822010556
50	-	-	0822010527	0822010537	0822010547	0822010557

Piston Ø Piston rod thread Ports	50 mm M8 G 1/8	63 mm M8 G 1/8	80 mm M10 G 1/4	100 mm M12 G 1/4
Stroke 5	-	0822010570	-	-
10	0822010561	0822010571	R402005784	-
15	0822010562	0822010572	-	-
20	0822010563	0822010573	-	-
25	0822010564	0822010574	R402005787	R402005833
30	0822010565	0822010575	-	-

Piston Ø Piston rod thread Ports	50 mm M8 G 1/8	63 mm M8 G 1/8	80 mm M10 G 1/4	100 mm M12 G 1/4
40	0822010566	0822010576	-	-
50	0822010567	0822010577	R402005790	R402005836

Other versions can be ordered from AVENTICS sales offices.

## Technical data

Piston Ø	12 mm	16 mm	20 mm	25 mm
Retracting piston force	53 N	95 N	148 N	260 N
Extracting piston force	71 N	127 N	198 N	309 N
Impact energy	0,03 J	0,06 J	0,08 J	0,1 J
Weight 0 mm stroke	0,036 kg	0,063 kg	0,082 kg	0,164 kg
Weight +10 mm stroke	0,013 kg	0,016 kg	0,021 kg	0,03 kg
Working pressure min./max.	1 ... 10 bar	1 ... 10 bar	1 ... 10 bar	1 ... 10 bar
Material, front cover	Brass	Brass	Brass	Brass

Piston Ø	32 mm	40 mm	50 mm	63 mm
Retracting piston force	435 N	720 N	1110 N	1837 N
Extracting piston force	507 N	792 N	1237 N	1964 N
Impact energy	0,16 J	0,24 J	0,32 J	0,38 J
Weight 0 mm stroke	0,195 kg	0,285 kg	0,388 kg	0,636 kg
Weight +10 mm stroke	0,042 kg	0,052 kg	0,074 kg	0,096 kg
Working pressure min./max.	0,6 ... 10 bar	0,6 ... 10 bar	0,6 ... 10 bar	0,6 ... 10 bar
Material, front cover	Aluminum	Aluminum	Aluminum	Aluminum

Piston Ø	80 mm	100 mm
Retracting piston force	2857 N	4939 N
Extracting piston force	3167 N	4948 N
Impact energy	0,38 J	0,5 J
Weight 0 mm stroke	1,22 kg	2,38 kg
Weight +10 mm stroke	0,149 kg	0,218 kg
Working pressure min./max.	0,6 ... 10 bar	0,6 ... 10 bar
Material, front cover	Aluminum	Aluminum

## Technical information

The pressure dew point must be at least 15 °C under ambient and medium temperature and may not exceed 3 °C .

The oil content of compressed air must remain constant during the life cycle.

Use only the approved oils from AVENTICS. Further information can be found in the "Technical information" document (available in the MediaCentre).

## Technical information

Material	
Cylinder tube	Aluminum, anodized
Piston rod	Stainless steel

Material	
Piston	Nitrile rubber
Front cover	Brass, Aluminum
End cover	Aluminum
Scraper	Polyurethane

## Dimensions

### Dimensions

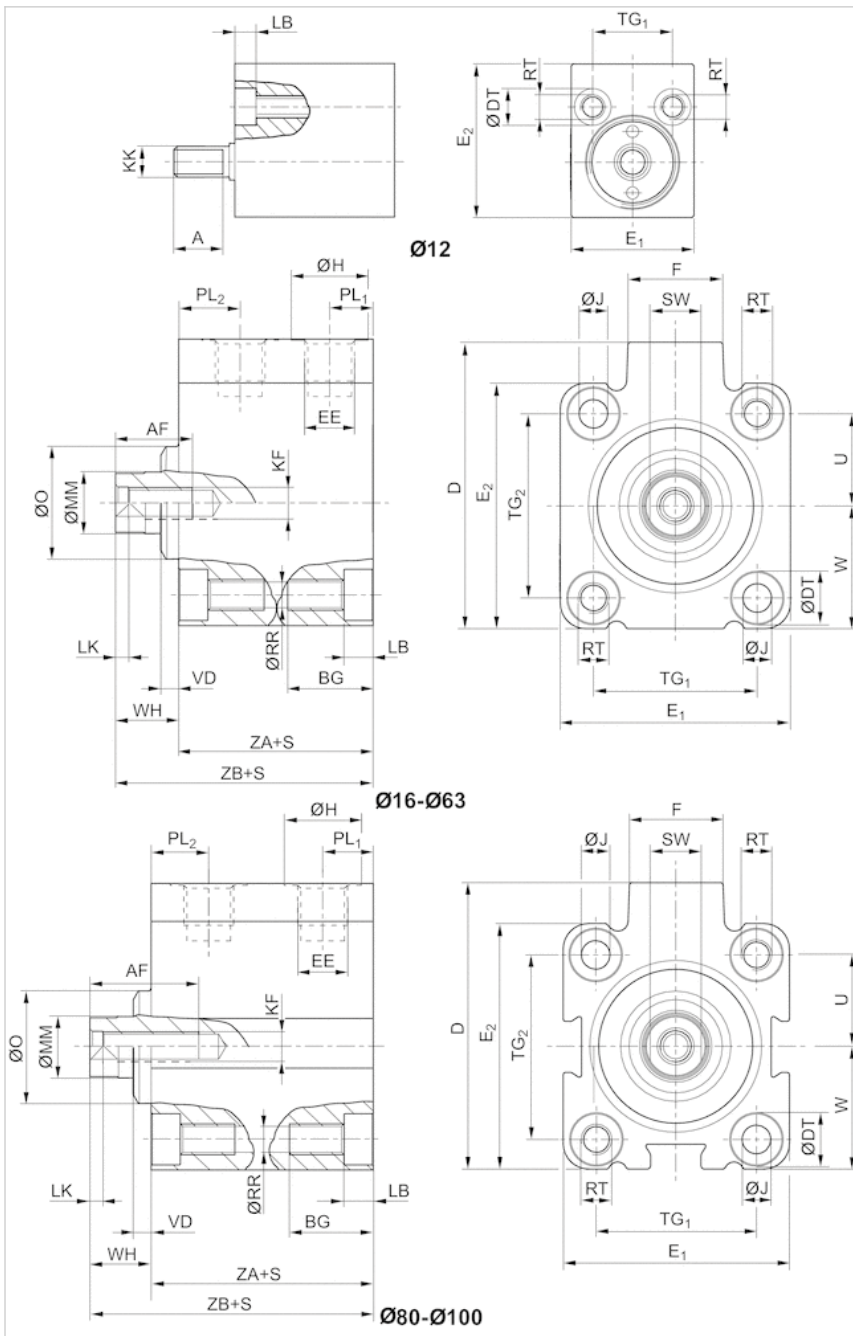

S = stroke

## Dimensions

Piston Ø	S	A	AF+1	BG 1)	DJS15	ØDTH13	E1JS15	E2JS15	EE	F	ØH	ØJ	KF	KK
12 mm	5 - 20	8	-	12.4	-	6	20	25	M 5	-	8	-	-	M 5
12 mm	25 - 40	8	-	17.5	-	6	20	25	M 5	-	8	-	-	M 5
16 mm	5 - 15	-	10	12.4	33	6	28	28	M 5	11.5	8	3.55	M5	-
16 mm	20 - 40	-	10	17.5	33	6	28	28	M 5	11.5	8	3.55	M5	-
20 mm	5 - 50	-	10	13.6	37	7.5	32	32	M 5	11	8	4.55	M5	-
25 mm	5 - 50	-	10	13.6	47.5	8	37	39	G 1/8	17.5	15	4.55	M5	-
32 mm	5 - 50	-	15	16.7	56	10	45	48	G 1/8	18.5	15	5.5	M6	-
40 mm	5 - 50	-	15	16.7	62.5	10	54.5	54.5	G 1/8	18.5	15	5.5	M6	-
50 mm	10 - 50	-	18	19.8	72	11	64	64	G 1/8	18	15	7.3	M8	-
63 mm	5 - 50	-	18	25	88	15	80	80	G 1/8	23	15	9.2	M8	-
80 mm	10 - 50	-	18	25	110	15	100	100	G 1/4	27	19	9.2	M10	-
100 mm	25 - 50	-	20	30	132	17.5	124	124	G 1/4	28	19	11	M12	-

Piston Ø	LB+0,4	LK+0,5	ØMMf8	ØO	PL1	PL2	ØRR	RT	SW-0,3	TG1	TG2	U	W
12 mm	3.4	-	6	-	6	9.5	3.3	M4	-	13 ±0,2	-	9	9 ±0,2
12 mm	8.5	-	6	-	6	9.5	3.3	M4	-	13 ±0,2	-	9	9 ±0,2
16 mm	3.4	2	8	-	6	11.3	3.3	M4	7	20 ±0,2	20 ±0,2	10	14 ±0,2
16 mm	8.5	2	8	-	6	11.3	3.3	M4	7	20 ±0,2	20 ±0,2	10	14 ±0,2
20 mm	4.6	2	10	-	5	8	4.2	M5	8	22 ±0,2	22 ±0,2	11	16 ±0,2
25 mm	4.6	2	10	20	9	11	4.2	M5	8	26 ±0,25	28 ±0,25	14	19,5 ±0,2
32 mm	5.7	2.5	12	22	8.5	12	5.05	M6	10	32 ±0,25	36 ±0,25	18	24 ±0,2
40 mm	5.7	2.5	12	30	9	11	5.05	M6	10	40 ±0,25	40 ±0,25	20	27,3 ±0,2
50 mm	6.8	3.5	16	35	8.5	11	6.8	M8	13	50 ±0,25	50 ±0,25	25	32 ±0,2
63 mm	9	3.5	16	35	8.5	12.5	8.5	M10	13	62 ±0,25	62 ±0,25	31	40 ±0,2
80 mm	9	4	20	46	13	16	8.8	M10	17	82 ±0,3	82 ±0,3	41	50 ±0,3
100 mm	11	4	25	56	15.5	15.5	10.2	M12	22	103 ±0,3	103 ±0,3	51.5	62 ±0,3

Piston Ø	VD-1	WH	ZA±0,2	ZB±0,8
12 mm	-	-	21	31
12 mm	-	-	21	31
16 mm	-	6	25	31
16 mm	-	6	25	31
20 mm	-	9.5	24.5	34
25 mm	3.5	11.5	31	42.5
32 mm	3.5	12.5	33	45.5
40 mm	4.5	15	33	48
50 mm	6	17	32.5	49.5
63 mm	6.5	17	35.5	52.5
80 mm	8.5	18	42	60
100 mm	7	20	49.5	69.5

1) Min.

S = stroke

# Accessories overview

## Overview drawing

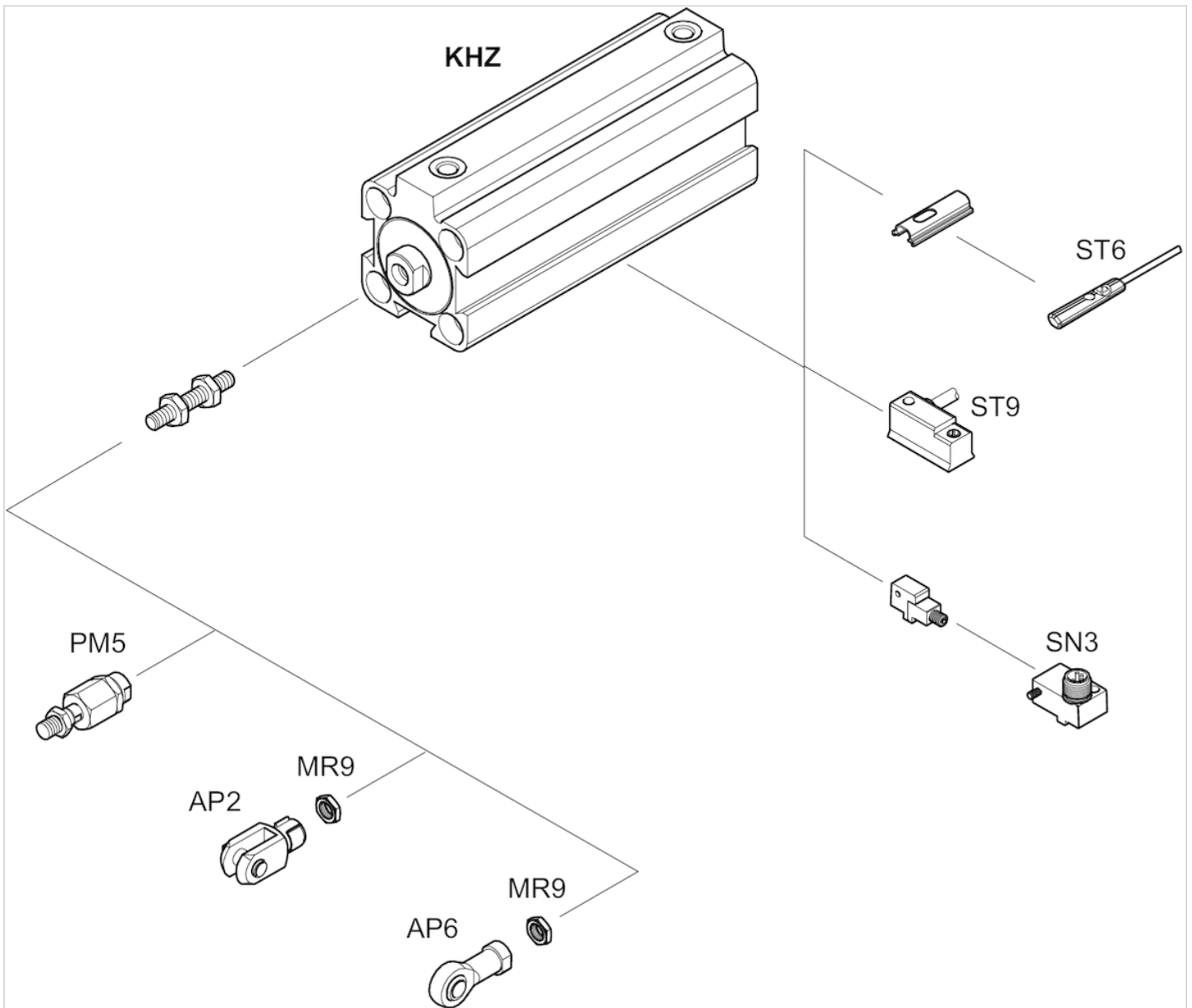

NOTE: This overview drawing is only for orientation to indicate where the various accessory parts can be fastened to the cylinder. The illustration has been simplified for this purpose. It is thus not possible to derive the dimensions from this overview.

# Short-stroke cylinder, Series KHZ

- Ø 12-100 mm
- Ports M5, G 1/8, G 1/4
- double-acting
- with magnetic piston
- Cushioning elastic
- Piston rod Internal thread



Compressed air connection	Internal thread
Ambient temperature min./max.	-25 ... 80 °C
Medium temperature min./max.	-25 ... 80 °C
Medium	Compressed air
Max. particle size	50 µm
Oil content of compressed air	0 ... 5 mg/m <sup>3</sup>
Pressure for determining piston forces	6.3 bar



## Technical data

Piston Ø Piston rod thread Ports	12 mm M3 M5	16 mm M5 M5	20 mm M5 M5	25 mm M5 G 1/8	32 mm M6 G 1/8	40 mm M6 G 1/8
Stroke 5	0822010600	0822010610	0822010620	0822010630	0822010640	0822010650
10	0822010601	0822010611	0822010621	0822010631	0822010641	0822010651
15	0822010602	0822010612	0822010622	0822010632	0822010642	0822010652
20	0822010603	0822010613	0822010623	0822010633	0822010643	0822010653
25	0822010604	0822010614	0822010624	0822010634	0822010644	0822010654
30	0822010605	0822010615	0822010625	0822010635	0822010645	0822010655
40	0822010606	0822010616	0822010626	0822010636	0822010646	0822010656
50	-	-	0822010627	0822010637	0822010647	0822010657
80	-	-	-	-	0822010648	0822010658
100	-	-	-	-	0822010649	0822010659

Piston Ø Piston rod thread Ports	50 mm M8 G 1/8	63 mm M8 G 1/8	80 mm M10 G 1/4	100 mm M12 G 1/4
Stroke 5	-	-	-	-
10	0822010661	0822010671	0822010681	0822010691
15	0822010662	0822010672	R402005794	-

Piston Ø Piston rod thread Ports	50 mm M8 G 1/8	63 mm M8 G 1/8	80 mm M10 G 1/4	100 mm M12 G 1/4
20	0822010663	0822010673	-	-
25	0822010664	0822010674	0822010684	0822010694
30	0822010665	0822010675	-	-
40	0822010666	0822010676	R402005797	R402005844
50	0822010667	0822010677	0822010687	0822010697
80	0822010668	0822010678	0822010688	0822010698
100	0822010669	0822010679	0822010689	0822010699

Other versions can be ordered from AVENTICS sales offices.

## Technical data

Piston Ø	12 mm	16 mm	20 mm	25 mm
Retracting piston force	53 N	95 N	148 N	260 N
Extracting piston force	71 N	127 N	198 N	309 N
Impact energy	0,03 J	0,06 J	0,08 J	0,1 J
Weight 0 mm stroke	0,05 kg	0,065 kg	0,092 kg	0,178 kg
Weight +10 mm stroke	0,013 kg	0,016 kg	0,021 kg	0,03 kg
Working pressure min./max.	1 ... 10 bar	1 ... 10 bar	1 ... 10 bar	1 ... 10 bar
Material, front cover	Brass	Brass	Brass	Brass

Piston Ø	32 mm	40 mm	50 mm	63 mm
Retracting piston force	435 N	720 N	1110 N	1837 N
Extracting piston force	507 N	792 N	1237 N	1964 N
Impact energy	0,16 J	0,24 J	0,32 J	0,38 J
Weight 0 mm stroke	0,195 kg	0,285 kg	0,388 kg	0,636 kg
Weight +10 mm stroke	0,042 kg	0,052 kg	0,074 kg	0,096 kg
Working pressure min./max.	0,6 ... 10 bar	0,6 ... 10 bar	0,6 ... 10 bar	0,6 ... 10 bar
Material, front cover	Aluminum	Aluminum	Aluminum	Aluminum

Piston Ø	80 mm	100 mm
Retracting piston force	2857 N	4639 N
Extracting piston force	3167 N	4948 N
Impact energy	0,38 J	0,5 J
Weight 0 mm stroke	1,22 kg	2,38 kg
Weight +10 mm stroke	0,149 kg	0,218 kg
Working pressure min./max.	0,6 ... 10 bar	0,6 ... 10 bar
Material, front cover	Aluminum	Aluminum

## Technical information

The pressure dew point must be at least 15 °C under ambient and medium temperature and may not exceed 3 °C .

The oil content of compressed air must remain constant during the life cycle.

Use only the approved oils from AVENTICS. Further information can be found in the "Technical information" document (available in the MediaCentre).

## Technical information

Material	
Cylinder tube	Aluminum, anodized
Piston rod	Stainless steel
Piston	Nitrile rubber
Front cover	Brass, Aluminum
End cover	Aluminum
Scraper	Polyurethane

# Dimensions

## Dimensions

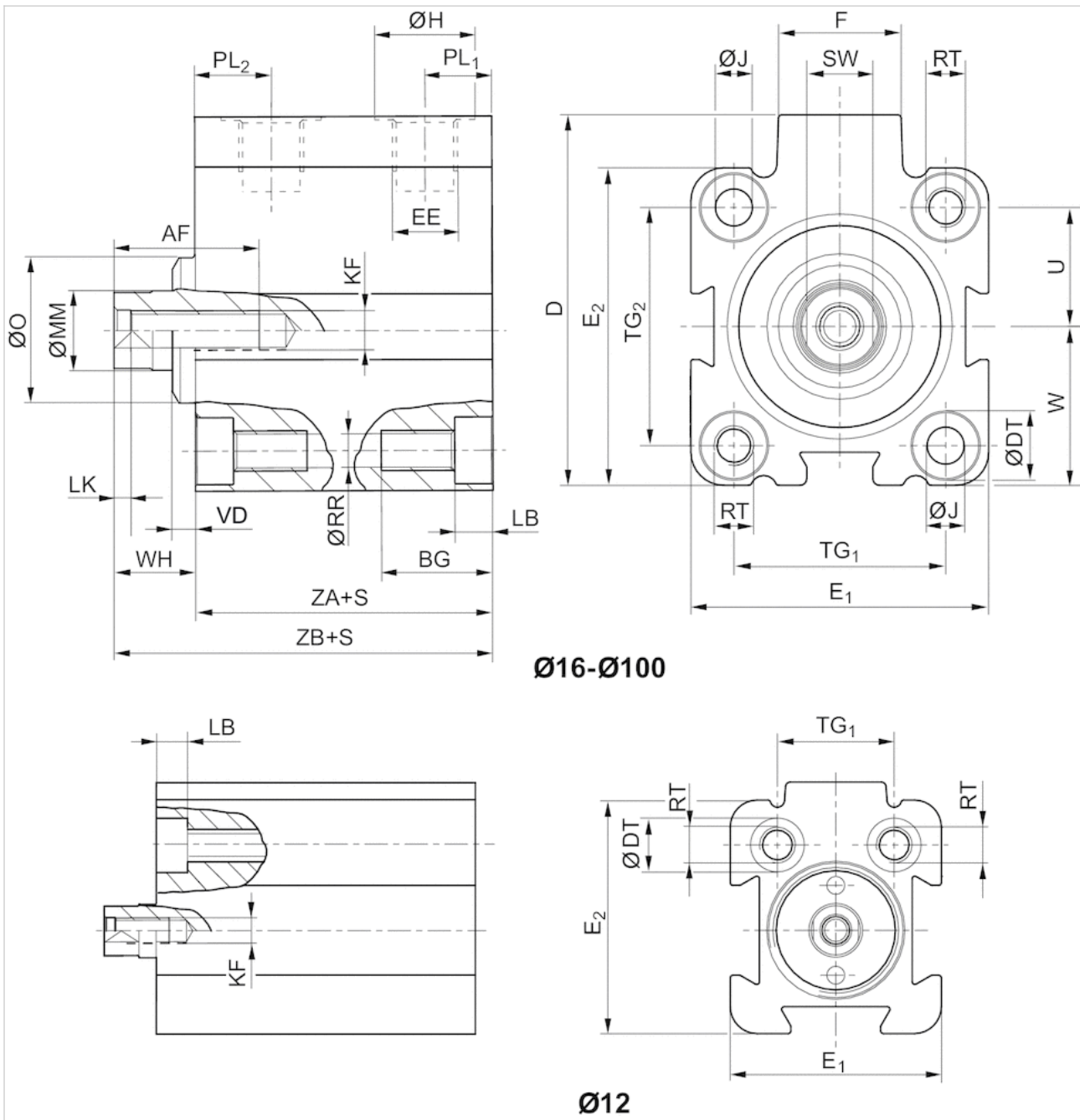

**Ø16-Ø100**

**Ø12**

S = stroke

## Dimensions

Piston Ø	S	AF+1	BG 1)	DJS15	ØDTH13	E1JS15	E2JS15	EE	F	ØH	ØJ	KF	LB+0,4
12 mm	5 - 10	8	12.4	28	6	23.5	26	M 5	11	8	3.3	M3	3.4
12 mm	-	-	-	-	-	-	-	-	-	-	-	-	-
12 mm	15 - 40	8	17.5	28	6	23.5	26	M 5	11	8	3.3	M3	8.5
12 mm	-	-	-	-	-	-	-	-	-	-	-	-	-
16 mm	5 - 10	10	12.4	33	6	28	28	M 5	11.5	8	3.55	M5	3.4
16 mm	-	-	-	-	-	-	-	-	-	-	-	-	-
16 mm	15 - 40	10	17.5	33	6	28	28	M 5	11.5	8	3.55	M5	8.5
16 mm	-	-	-	-	-	-	-	-	-	-	-	-	-
20 mm	5 - 10	10	13.6	37	7.5	32	32	M 5	11	8	4.55	M5	4.6
20 mm	15 - 50	10	13.6	37	7.5	32	32	M 5	11	8	4.55	M5	4.6
25 mm	5 - 50	10	13.6	47.5	8	37	39	G 1/8	17.5	15	4.55	M5	4.6
32 mm	5 - 100	15	16.7	56	10	45	48	G 1/8	18.5	15	5.5	M6	5.7
40 mm	5 - 100	15	16.7	62.5	10	54.5	54	G 1/8	18.5	15	5.5	M6	5.7
50 mm	10 - 100	18	19.8	73	11	66	66	G 1/8	18	15	7.3	M8	6.8
63 mm	10 - 100	18	25	88	15	80	80	G 1/8	23	15	9.2	M8	9
80 mm	10 - 100	18	25	110	15	100	100	G 1/4	27	19	9.2	M10	9
100 mm	10 - 100	20	30	132	17.5	124	124	G 1/4	28	19	11	M12	11

Piston Ø	LK+0,5	ØMMf8	ØO	PL1	PL2	ØRR	RT	SW-0,3	TG1	TG2	U	W	VD-1
12 mm	2	6	-	6	10.5	3.3	M4	5	13 ±0,2	-	9.5	11,5 ±0,2	-
12 mm	-	-	-	-	-	-	-	-	-	-	-	-	-
12 mm	2	6	-	6	10.5	3.3	M4	5	13 ±0,2	-	9.5	11,5 ±0,2	-
12 mm	-	-	-	-	-	-	-	-	-	-	-	-	-
16 mm	2	8	-	6.5	11.3	3.3	M4	7	20 ±0,2	20 ±0,2	10	14 ±0,2	-
16 mm	-	-	-	-	-	-	-	-	-	-	-	-	-
16 mm	2	8	-	6.5	11.3	3.3	M4	7	20 ±0,2	20 ±0,2	10	14 ±0,2	-
16 mm	-	-	-	-	-	-	-	-	-	-	-	-	-
20 mm	2	10	-	6.5	10	4.2	M5	8	22 ±0,2	22 ±0,2	11	16 ±0,2	-
20 mm	2	10	-	6.5	10	4.2	M5	8	22 ±0,2	22 ±0,2	11	16 ±0,2	-
25 mm	2	10	20	9.5	11.5	4.2	M5	8	26 ±0,25	28 ±0,25	14	19,5 ±0,2	3.5
32 mm	2.5	12	22	8.5	15	5.05	M6	10	32 ±0,25	36 ±0,25	18	24 ±0,2	3.5
40 mm	2.5	12	30	10	13.5	5.05	M6	10	40 ±0,25	40 ±0,25	20	27,3 ±0,2	4.5
50 mm	3.5	16	35	10	14	6.8	M8	13	50 ±0,25	50 ±0,25	25	33 ±0,2	6
63 mm	3.5	16	35	11.5	14	8.5	M10	13	62 ±0,25	62 ±0,25	31	40 ±0,2	6.5
80 mm	4	20	46	12	15.5	8.5	M10	17	82 ±0,3	82 ±0,3	41	50 ±0,3	8.5
100 mm	4	25	56	12	18.5	10.2	M12	22	103 ±0,3	103 ±0,3	51.5	62 ±0,3	7

Piston Ø	WH	ZA±0,2	ZB±0,8
12 mm	5.5	30.5	36
12 mm	-	-	-
12 mm	5.5	30.5	36
12 mm	-	-	-
16 mm	4.5	32	36.5
16 mm	-	-	-
16 mm	4.5	38	42.5
16 mm	-	-	-

Piston Ø	WH	ZA±0,2	ZB±0,8
20 mm	4.5	32	36.5
20 mm	4.5	38	42.5
25 mm	9.5	39	48.5
32 mm	11	39.5	50.5
40 mm	13.5	39.5	53
50 mm	13.5	39.5	53
63 mm	15.5	42	57.5
80 mm	18	46	64
100 mm	20	56	76

1) Min.  
S = stroke

## Accessories overview

### Overview drawing

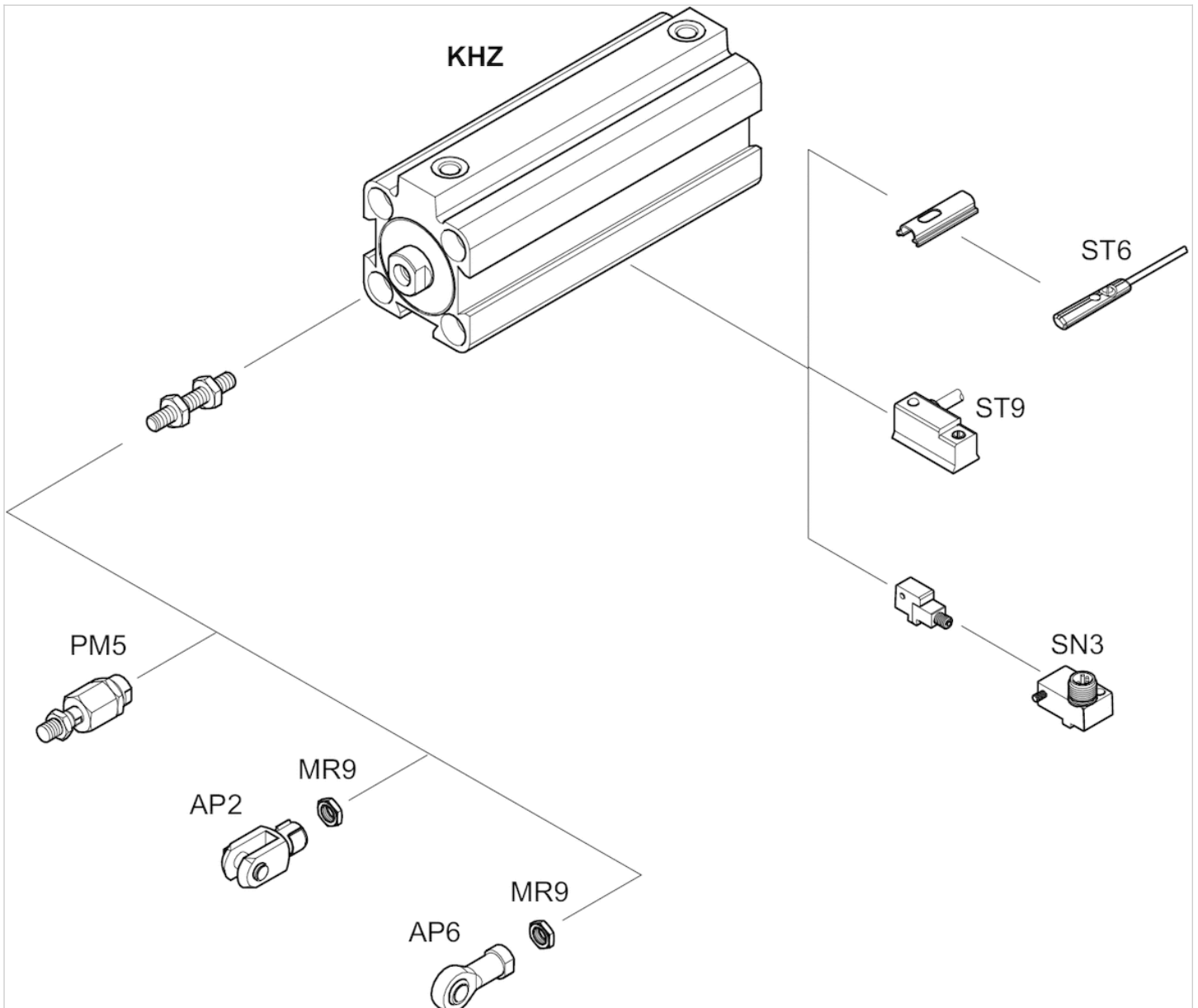

NOTE: This overview drawing is only for orientation to indicate where the various accessory parts can be fastened to the cylinder. The

illustration has been simplified for this purpose. It is thus not possible to derive the dimensions from this overview.

# Short-stroke cylinder, Series KHZ

- Ø 20-63 mm
- Ports M5, G 1/8
- double-acting
- Cushioning elastic
- Piston rod Internal thread
- Piston rod non-rotating



Compressed air connection	Internal thread
Ambient temperature min./max.	-25 ... 80 °C
Medium temperature min./max.	-25 ... 80 °C
Medium	Compressed air
Max. particle size	50 µm
Oil content of compressed air	0 ... 5 mg/m <sup>3</sup>
Pressure for determining piston forces	6.3 bar

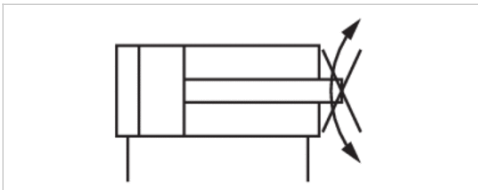

## Technical data

Piston Ø	20 mm	25 mm	32 mm	40 mm	50 mm	63 mm
Stroke 10	0822010721	0822010731	0822010741	0822010751	0822010761	0822010771
15	0822010722	0822010732	0822010742	0822010752	0822010762	0822010772
20	0822010723	0822010733	0822010743	0822010753	0822010763	0822010773
25	0822010724	0822010734	0822010744	0822010754	0822010764	0822010774
30	0822010725	0822010735	0822010745	0822010755	0822010765	0822010775
40	0822010726	0822010736	0822010746	0822010756	0822010766	0822010776
50	0822010727	0822010737	0822010747	0822010757	0822010767	0822010777

Other versions can be ordered from AVENTICS sales offices.

## Technical data

Piston Ø	20 mm	25 mm	32 mm	40 mm
Retracting piston force	148 N	260 N	435 N	720 N
Extracting piston force	198 N	309 N	507 N	792 N
Impact energy	0,08 J	0,1 J	0,16 J	0,24 J
Weight 0 mm stroke	0,092 kg	0,178 kg	0,195 kg	0,285 kg
Weight +10 mm stroke	0,024 kg	0,034 kg	0,05 kg	0,06 kg

Piston Ø	20 mm	25 mm	32 mm	40 mm
Working pressure min./max.	1 ... 10 bar	1 ... 10 bar	0,6 ... 10 bar	0,6 ... 10 bar
Material, front cover	Brass	Brass	Aluminum	Aluminum

Piston Ø	50 mm	63 mm
Retracting piston force	1110 N	1837 N
Extracting piston force	1237 N	1964 N
Impact energy	0,32 J	0,38 J
Weight 0 mm stroke	0,388 kg	0,636 kg
Weight +10 mm stroke	0,086 kg	0,114 kg
Working pressure min./max.	0,6 ... 10 bar	0,6 ... 10 bar
Material, front cover	Aluminum	Aluminum

## Technical information

The pressure dew point must be at least 15 °C under ambient and medium temperature and may not exceed 3 °C .

The oil content of compressed air must remain constant during the life cycle.

Use only the approved oils from AVENTICS. Further information can be found in the "Technical information" document (available in the MediaCentre).

## Technical information

Material	
Cylinder tube	Aluminum, anodized
Piston rod	Stainless steel
Piston	Nitrile rubber
Front cover	Brass, Aluminum
End cover	Aluminum
Scraper	Polyurethane

## Dimensions

### Dimensions

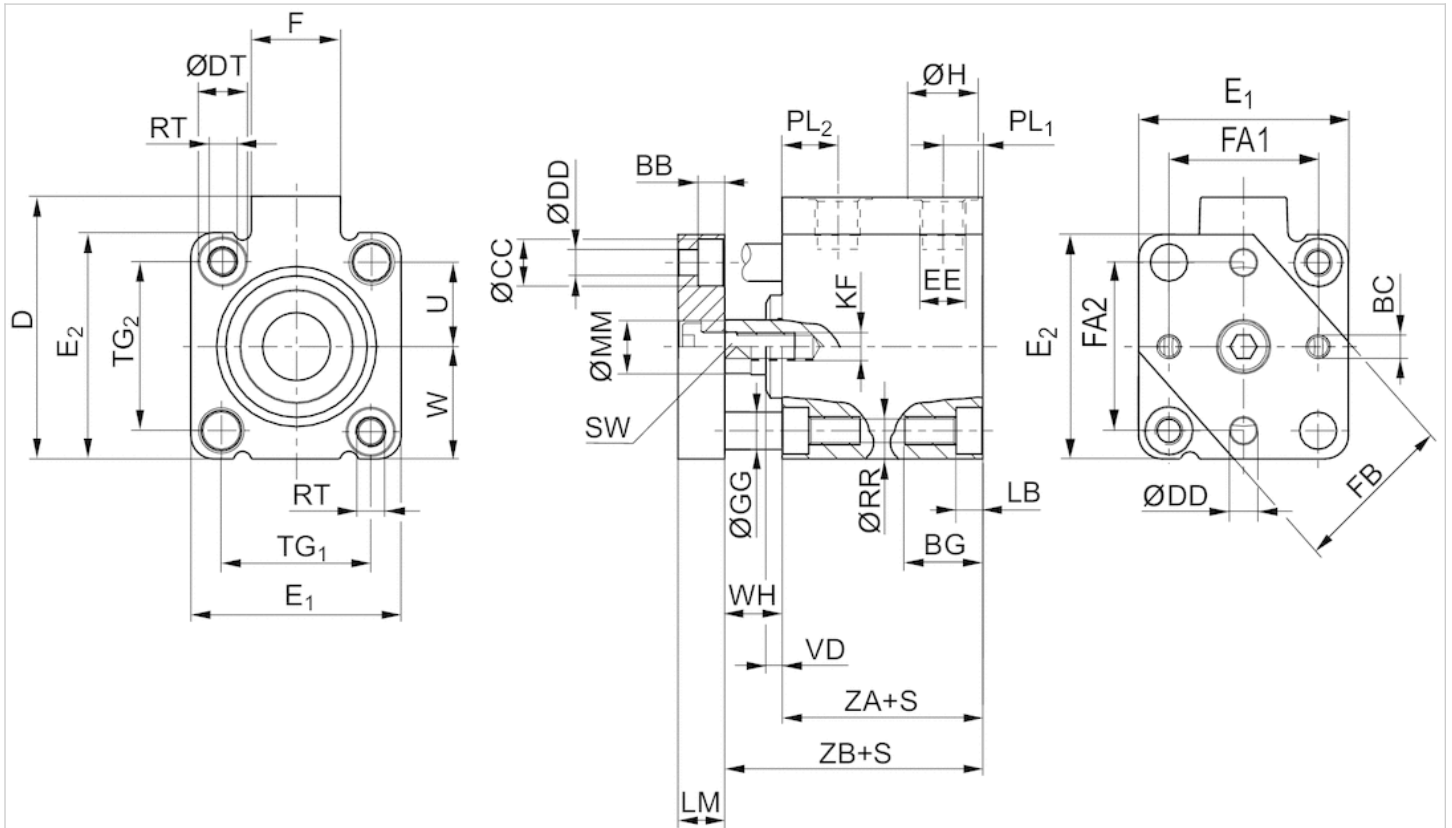

## Dimensions

Piston Ø	S	BB	BC	BG <sup>1)</sup>	ØCC	DJS15	ØDD	ØDTH13	E1JS15	E2JS15	EE	F	FB
20 mm	10 - 50	5	M 4	13.6	7.5	37	4.5	7.5	32	32	M 5	11	25
25 mm	10 - 50	5	M 4	13.6	8	47.5	4.5	8	37	39	G 1/8	17,5	30
32 mm	10 - 50	5,7	M 5	16.7	10	56	5.5	10	45	48	G 1/8	18.5	35
40 mm	10 - 50	5,7	M 5	16.7	10	62.5	5.5	10	54.5	54.5	G 1/8	18.5	40
50 mm	10 - 50	6,8	M 6	19.8	11	72	6.5	11	64	64	G 1/8	18	50
63 mm	10 - 50	9	M 6	25	14	88	9	15	80	80	G 1/8	23	60

Piston Ø	ØGG-0,005/-0,025	ØH	KF	LB+0,4	LM	ØMMf8	PL1	PL2	ØRR	RT	SW-0,3	TG1
20 mm	5	8	M 5	4.6	8	10	5	8	4.2	M 5	8	22 ±0,2
25 mm	6	15	M 5	4.6	8	10	9	11	4.2	M 5	8	26 ±0,25
32 mm	8	15	M 6	5.7	10	12	8.5	12	5.05	M 6	10	32 ±0,25
40 mm	8	15	M 6	5.7	10	12	9	11	5.05	M 6	10	40 ±0,25
50 mm	10	15	M 8	6.8	12	16	8,5	11	6.8	M 8	13	50 ±0,25
63 mm	12	15	M 8	9	12	16	8,5	12,5	8.5	M 10	13	62 ±0,25

Piston Ø	TG2	U	W	VD-1	WH	FA1±0,1	FA2±0,1	ZA±0,2	ZB±0,8
20 mm	22 ±0,2	11	16 ±0,2	-	9,5	22	22	24.5	34
25 mm	28 ±0,25	14	19,5 ±0,2	3.5	11,5	26	28	31	42.5
32 mm	36 ±0,25	18	24 ±0,2	3.5	12,5	32	36	33	45.5
40 mm	40 ±0,25	20	27,3 ±0,2	4.5	15	40	40	33	48
50 mm	50 ±0,25	25	32 ±0,2	6	17	50	50	32.5	49.5

Piston Ø	TG2	U	W	VD-1	WH	FA1±0,1	FA2±0,1	ZA±0,2	ZB±0,8
63 mm	62 ±0,25	31	40 ±0,2	6.5	17	62	62	35.5	52.5

Max. permissible torque Dynamic

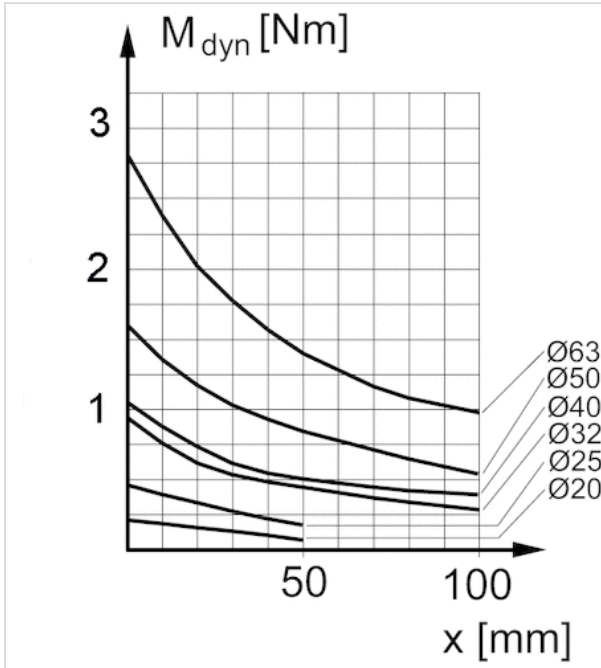

X = distance between force application point and cylinder cover

Diagrams

Maximum admissible lateral force static

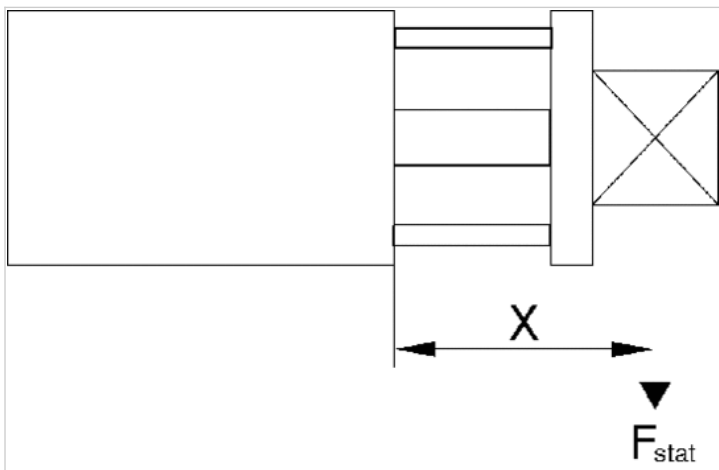

F stat. = static lateral force

X = distance between force application point and cylinder cover

Maximum admissible lateral force static

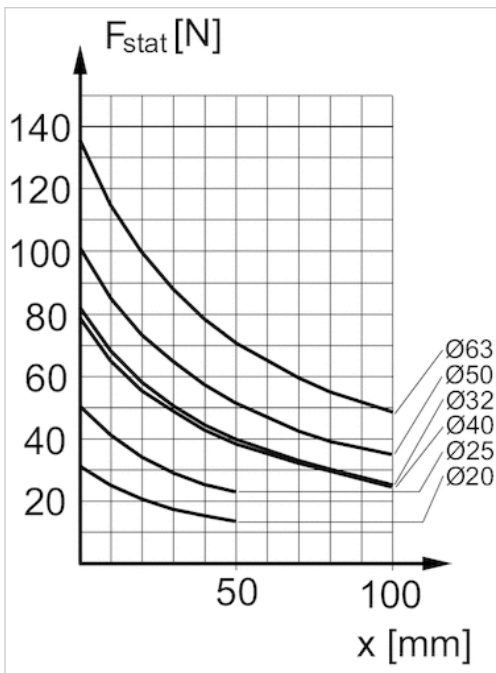

$F_{stat}$  = static lateral force  
 $X$  = distance between force application point and cylinder cover

Maximum admissible lateral force dynamic

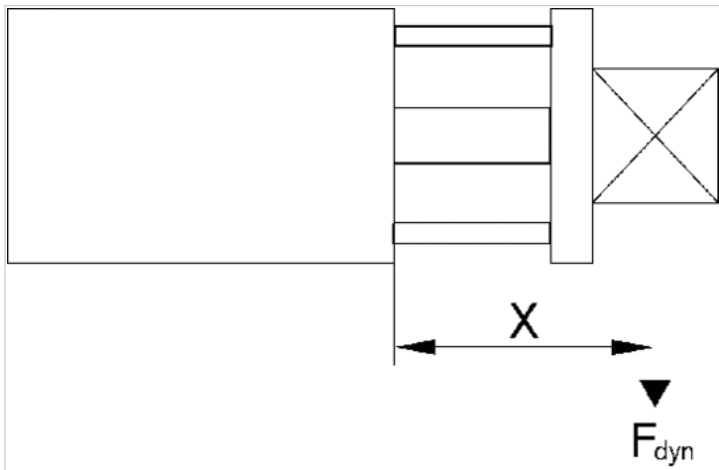

$F_{dyn}$  = dynamic lateral force  
 $X$  = distance between force application point and cylinder cover

Maximum admissible lateral force dynamic

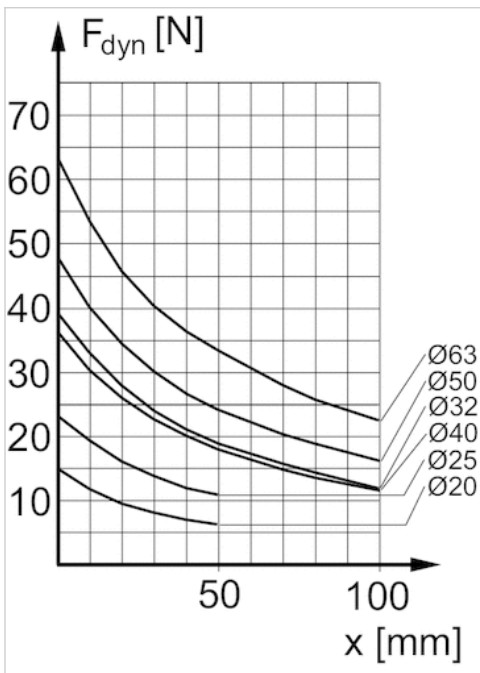

$F_{dyn}$  = dynamic lateral force  
 $x$  = distance between force application point and cylinder cover

Max. permissible torque static

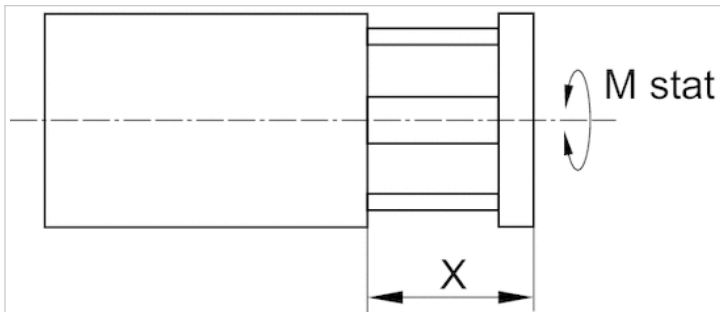

Max. permissible torque static

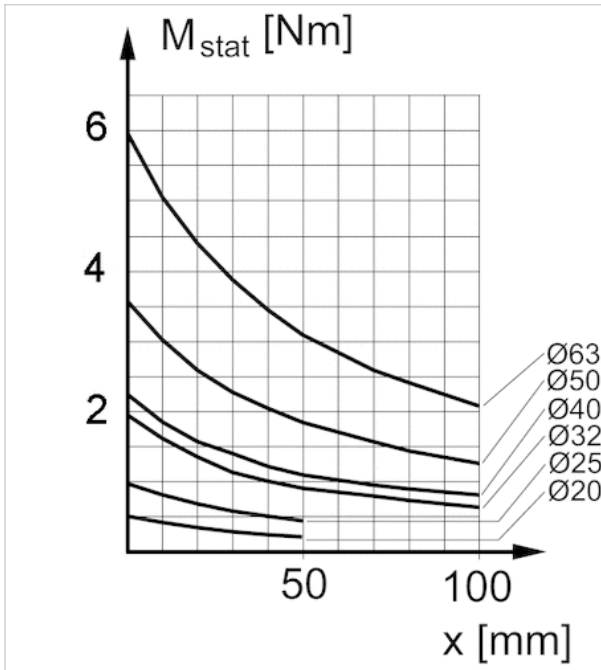

X = distance between force application point and cylinder cover

Max. permissible torque dynamic

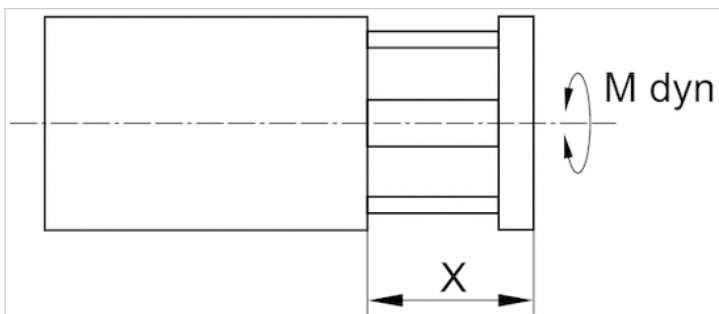

## Accessories overview

### Overview drawing

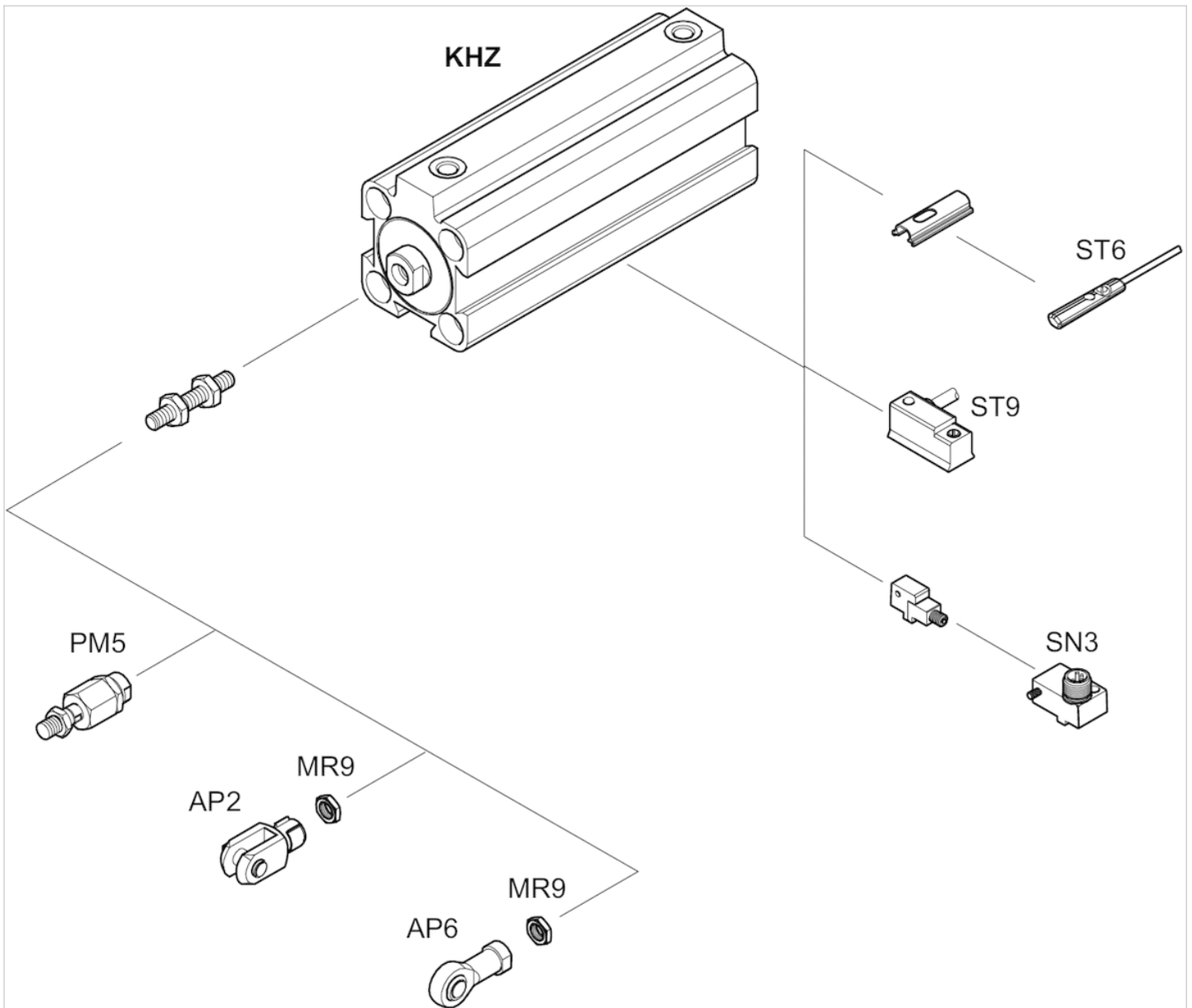

NOTE: This overview drawing is only for orientation to indicate where the various accessory parts can be fastened to the cylinder. The illustration has been simplified for this purpose. It is thus not possible to derive the dimensions from this overview.

# Short-stroke cylinder, Series KHZ

- Ø 16-100 mm
- Ports M5, G 1/8, G 1/4
- double-acting
- with magnetic piston
- Cushioning elastic
- Piston rod Internal thread
- Piston rod non-rotating

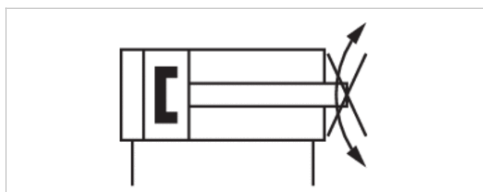

Compressed air connection	Internal thread
Ambient temperature min./max.	-25 ... 80 °C
Medium temperature min./max.	-25 ... 80 °C
Medium	Compressed air
Max. particle size	50 µm
Oil content of compressed air	0 ... 5 mg/m <sup>3</sup>
Pressure for determining piston forces	6.3 bar

## Technical data

Piston Ø	16 mm	20 mm	25 mm	32 mm	40 mm	50 mm	63 mm
Stroke 10	0822010811	0822010821	0822010831	0822010841	0822010851	0822010861	0822010871
15	0822010812	0822010822	0822010832	0822010842	0822010852	0822010862	0822010872
20	0822010813	0822010823	0822010833	0822010843	0822010853	0822010863	0822010873
25	0822010814	0822010824	0822010834	0822010844	0822010854	0822010864	0822010874
30	0822010815	0822010825	0822010835	0822010845	0822010855	0822010865	0822010875
40	0822010816	0822010826	0822010836	0822010846	0822010856	0822010866	0822010876
50	0822010817	0822010827	0822010837	0822010847	0822010857	0822010867	0822010877
80	-	-	-	0822010848	0822010858	0822010868	0822010878
100	-	-	-	0822010849	0822010859	0822010869	0822010879

Piston Ø	80 mm	100 mm
Stroke 10	0822010881	0822010891
15	-	-
20	-	-
25	0822010884	0822010894
30	-	-

Piston Ø	80 mm	100 mm
40	-	-
50	0822010887	0822010897
80	0822010888	0822010898
100	0822010889	0822010899

Other versions can be ordered from AVENTICS sales offices.

## Technical data

Piston Ø	16 mm	20 mm	25 mm	32 mm
Retracting piston force	95 N	148 N	260 N	435 N
Extracting piston force	127 N	198 N	309 N	507 N
Impact energy	0,06 J	0,08 J	0,1 J	0,16 J
Weight 0 mm stroke	0,084 kg	0,092 kg	0,178 kg	0,195 kg
Weight +10 mm stroke	0,018 kg	0,024 kg	0,034 kg	0,05 kg
Working pressure min./max.	1 ... 10 bar	1 ... 10 bar	1 ... 10 bar	0,6 ... 10 bar
Material, front cover	Brass	Brass	Brass	Aluminum

Piston Ø	40 mm	50 mm	63 mm	80 mm
Retracting piston force	720 N	1110 N	1766 N	2857 N
Extracting piston force	792 N	1237 N	1964 N	3167 N
Impact energy	0,24 J	0,32 J	0,38 J	0,38 J
Weight 0 mm stroke	0,285 kg	0,388 kg	0,636 kg	1,22 kg
Weight +10 mm stroke	0,06 kg	0,086 kg	0,114 kg	0,167 kg
Working pressure min./max.	0,6 ... 10 bar	0,6 ... 10 bar	0,6 ... 10 bar	0,6 ... 10 bar
Material, front cover	Aluminum	Aluminum	Aluminum	Aluminum

Piston Ø	100 mm
Retracting piston force	4639 N
Extracting piston force	4948 N
Impact energy	0,5 J
Weight 0 mm stroke	2,38 kg
Weight +10 mm stroke	0,242 kg
Working pressure min./max.	0,6 ... 10 bar
Material, front cover	Aluminum

## Technical information

The pressure dew point must be at least 15 °C under ambient and medium temperature and may not exceed 3 °C .

The oil content of compressed air must remain constant during the life cycle.

Use only the approved oils from AVENTICS. Further information can be found in the "Technical information" document (available in the MediaCentre).

## Technical information

Material	
Cylinder tube	Aluminum, anodized
Piston rod	Stainless steel
Piston	Nitrile rubber
Front cover	Brass, Aluminum
End cover	Aluminum
Scraper	Polyurethane

## Dimensions

### Dimensions

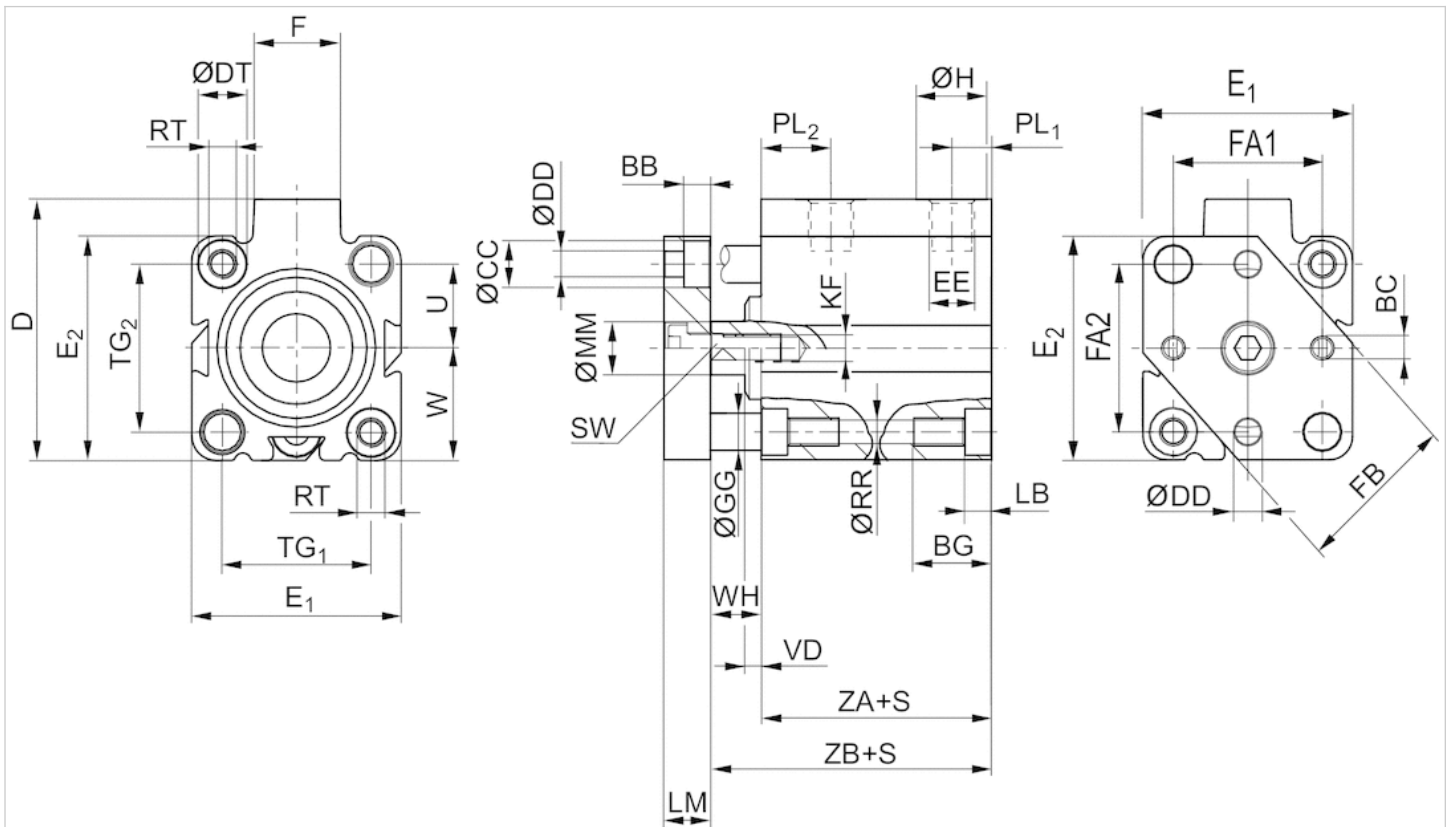

### Dimensions

Piston Ø	S	BB	BC	BG 1)	ØCC	DJS15	ØDD	ØDTH13	E1JS15	E2JS15	EE	F	FB
16 mm	10	3.5	M3	12.4	6	33	3.5	6	28	28	M5	11.5	20
16 mm	15 - 50	3.5	M3	17.5	6	33	3.5	6	28	28	M5	11.5	20
20 mm	10	5	M4	13.6	7.5	37	4.5	7.5	32	32	M5	11	25
20 mm	15 - 50	5	M4	13.6	7.5	37	4.5	7.5	32	32	M5	11	25
25 mm	10 - 50	5	M4	13.6	8	47.5	4.5	8	37	39	G 1/8	17.5	30
32 mm	10 - 100	5.7	M5	16.7	10	56	5.5	10	45	48	G 1/8	18.5	35
40 mm	10 - 100	5.7	M5	16.7	10	62.5	5.5	10	54.5	54.5	G 1/8	18.5	40
50 mm	10 - 100	6.8	M6	19.8	11	73	6.5	11	66	66	G 1/8	18	50

Piston Ø	S	BB	BC	BG 1)	ØCC	DJS15	ØDD	ØDTH13	E1JS15	E2JS15	EE	F	FB
63 mm	10 - 100	9	M6	25	14	88	9	15	80	80	G 1/8	23	60
80 mm	10/25/50/80/100	9	M8	25	14	110	9	15	100	100	G 1/4	27	75
100 mm	10/25/50/80/100	9	M8	30	14	132	9	17.5	124	124	G 1/4	28	90

Piston Ø	ØGG-0,005/-0,025	ØH	KF	LB+0,4	LM	ØMMf8	PL1	PL2	ØRR	RT	SW-0,3	TG1
16 mm	4	8	M 5	3.4	6	8	6.5	11.3	3.3	M4	7	20 ±0,2
16 mm	4	8	M 5	8.5	6	8	6.5	11.3	3.3	M4	7	20 ±0,2
20 mm	5	8	M 5	4.6	8	10	6.5	10	4.2	M5	8	22 ±0,2
20 mm	5	8	M 5	4.6	8	10	6.5	10	4.2	M5	8	22 ±0,2
25 mm	6	15	M 5	4.6	8	10	9.5	11.5	4.2	M5	8	26 ±0,25
32 mm	8	15	M 6	5.7	10	12	8.5	15	5.05	M6	10	32 ±0,25
40 mm	8	15	M 6	5.7	10	12	10	13.5	5.05	M6	10	40 ±0,25
50 mm	10	15	M 8	6.8	12	16	10	14	6.8	M8	13	50 ±0,25
63 mm	12	15	M 8	9	12	16	11.5	14	8.5	M10	13	62 ±0,25
80 mm	12	19	M 10	9	15	20	12	15.5	8.5	M10	17	82 ±0,3
100 mm	14	19	M 12	11	15	25	12	18.5	10.2	M12	22	103 ±0,3

Piston Ø	TG2	U	VD-1	W	WH	FA1±0,1	FA2±0,1	ZA±0,2	ZB±0,8
16 mm	20 ±0,2	10	-	14 ±0,2	4.5	20	20	32	36.5
16 mm	20 ±0,2	10	-	14 ±0,2	4.5	20	20	38	42.5
20 mm	22 ±0,2	11	-	16 ±0,2	4.5	22	22	32	36.5
20 mm	22 ±0,2	11	-	16 ±0,2	4.5	22	22	38	42.5
25 mm	28 ±0,25	14	3.5	19,5 ±0,2	9.5	26	28	39	48.5
32 mm	36 ±0,25	18	3.5	24 ±0,2	11	32	36	39.5	50.5
40 mm	40 ±0,25	20	4.5	27,3 ±0,2	13.5	40	40	39.5	53
50 mm	50 ±0,25	25	6	33 ±0,2	13.5	50	50	39.5	53
63 mm	62 ±0,25	31	6.5	40 ±0,2	15.5	62	62	42	57.5
80 mm	82 ±0,3	41	8.5	50 ±0,3	18	82	82	46	64
100 mm	103 ±0,3	51.5	7	62 ±0,3	20	103	103	56	76

M = max. permissible torque dynamic

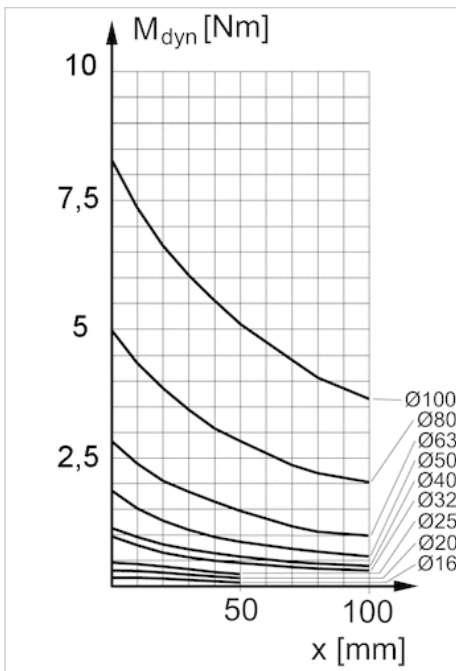

X = distance between force application point and cylinder cover

## Diagrams

Maximum admissible lateral force static

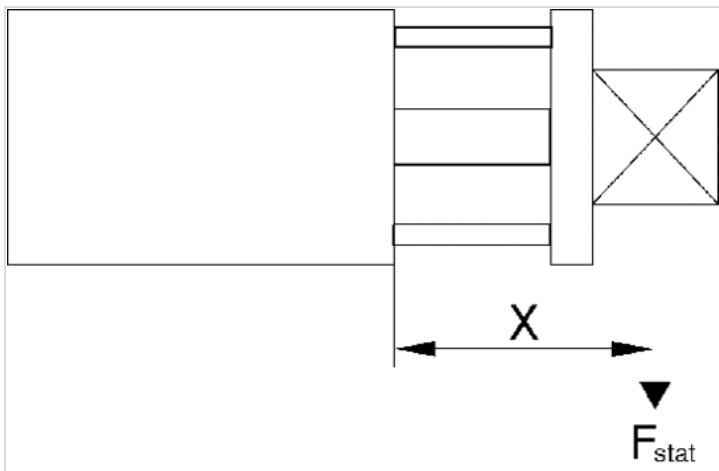

F stat. = static lateral force

X = distance between force application point and cylinder cover

Maximum admissible lateral force static

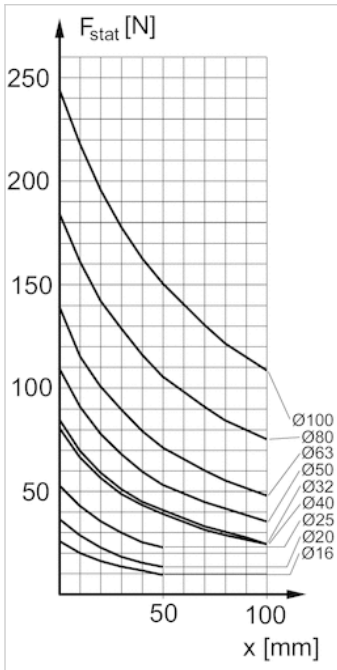

$F_{stat}$  = static lateral force  
 $X$  = distance between force application point and cylinder cover

Maximum admissible lateral force dynamic

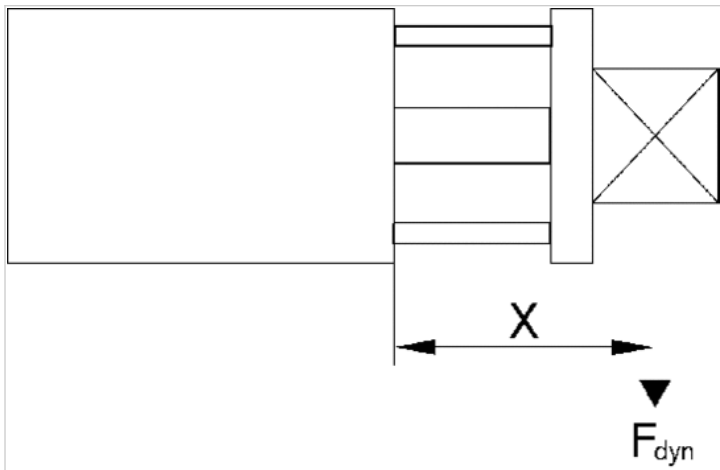

$F_{dyn}$  = dynamic lateral force  
 $X$  = distance between force application point and cylinder cover

Maximum admissible lateral force dynamic

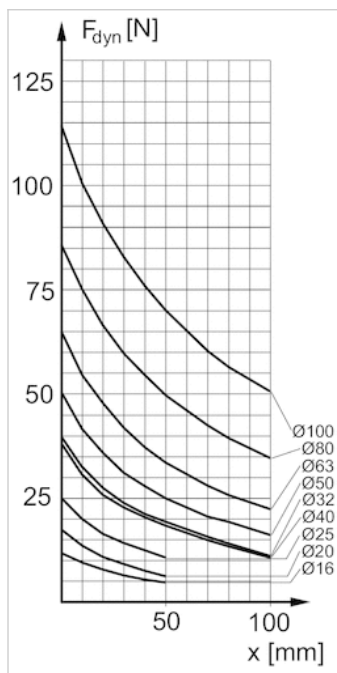

$F_{dyn}$  = dynamic lateral force  
 $X$  = distance between force application point and cylinder cover

Max. permissible torque static

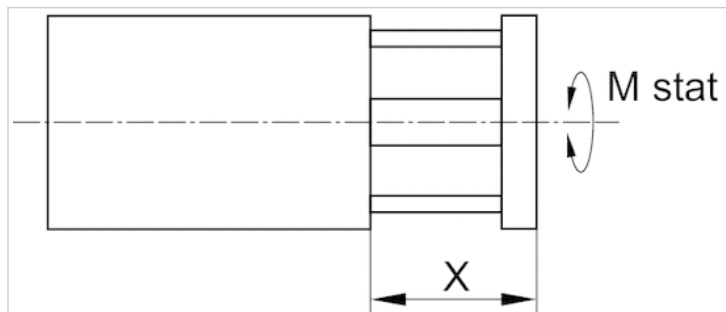

Max. permissible torque static

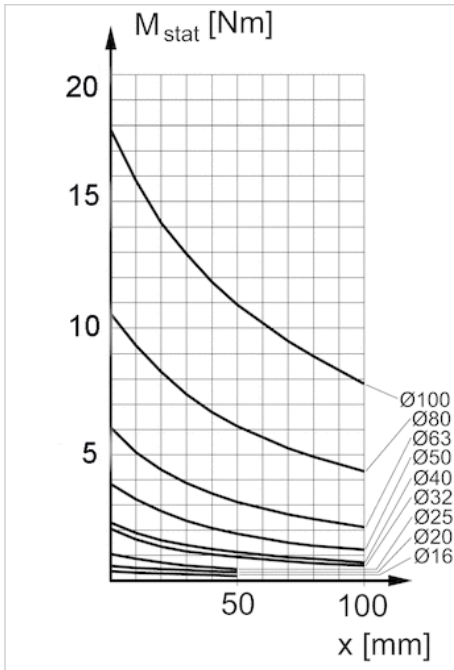

X = distance between force application point and cylinder cover

Max. permissible torque dynamic

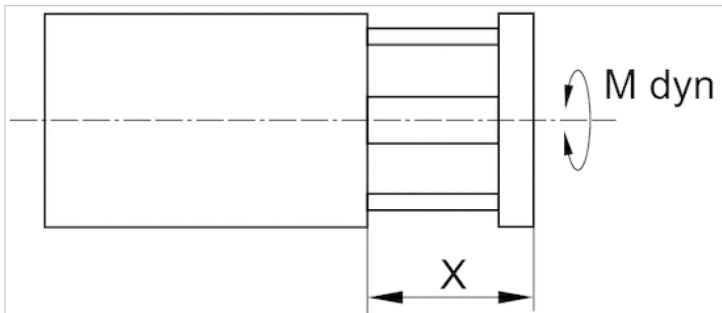

## Accessories overview

### Overview drawing

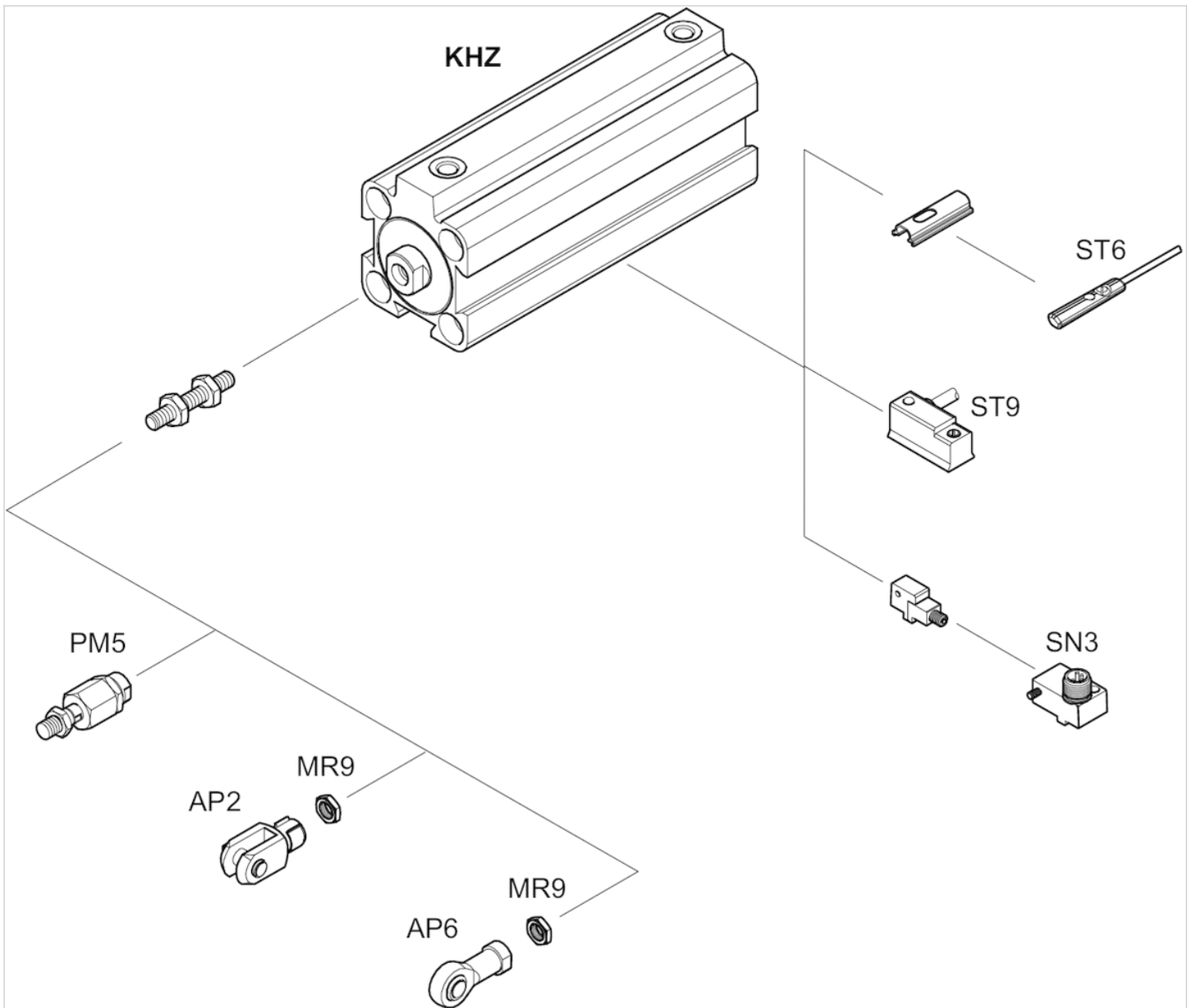

NOTE: This overview drawing is only for orientation to indicate where the various accessory parts can be fastened to the cylinder. The illustration has been simplified for this purpose. It is thus not possible to derive the dimensions from this overview.

# Nut for piston rod, Series MR9



Weight

See table below

## Technical data

Part No.	Suitable piston rod thread	Weight
1823300033	M6	0,004 kg
1823300034	M8	0,005 kg
8103040224	M10	0,011 kg
1823A00020	M10x1,25	0,01 kg

## Technical information

### Material

	Steel
	galvanized

## Dimensions

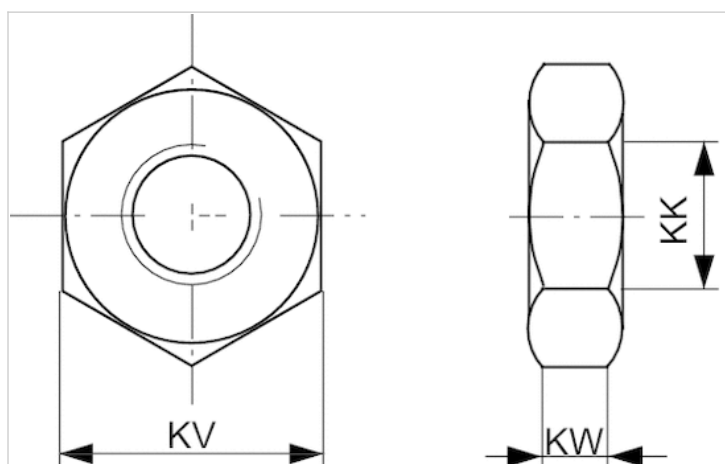

## Dimensions

Part No.	KK	KV	KW
1823300033	M6	10	3.2
1823300034	M8	13	4
8103040224	M10	17	8

# Rod clevis, Series AP2

- to mount on cylinder PRA, TRB, CCI, MNI, ICM, KPZ, KHZ, 167, CVI, RPC, RDC, ITS



Weight

See table below

## Technical data

Part No.	Suitable piston rod thread	for	Weight	Fig.
1822122009	M6	CCI, MNI, ICM, KHZ	0,02 kg	Fig. 1
1822122010	M8	CCI, MNI, ICM, KHZ	0,05 kg	Fig. 1
8958000122	M10	RPC, KHZ	0,1 kg	Fig. 1

## Technical information

### Material

Steel  
galvanized

## Dimensions

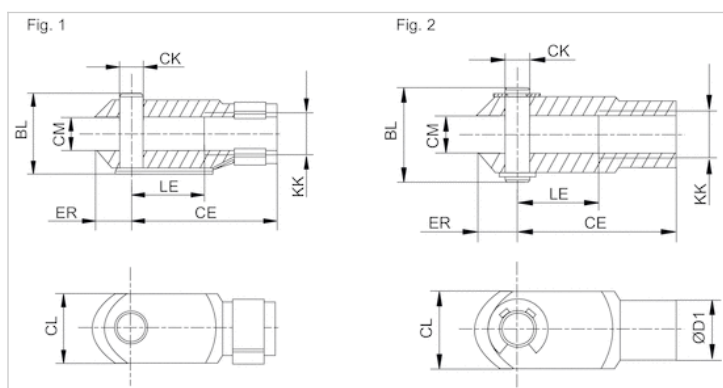

## Dimensions

Part No.	KK	BL	CE	ØCKe11	CL	CM	ØD1	ER	LE	Fig.
1822122009	M6	16	24	6	12	6	10	7	12	Fig. 1
1822122010	M8	21,5	32	8	16	8	14	10	16	Fig. 1
8958000122	M10	26	40	10	20	10	18	12	20	Fig. 1

# Ball eye rod end with flange, Series AP6

- to mount on cylinder PRA, TRB, CCI, SSI, MNI, RPC, KPZ, 167, CVI, RDC, 102, ITS



Weight

See table below

## Technical data

Part No.	Suitable piston rod thread	for	Swivel bearing Ø	Weight
			CN	
1822124001	M6	MNI, CCI, SSI	6 mm	0,03 kg
1822124002	M8	MNI, CCI, SSI, KPZ	8 mm	0,05 kg

## Technical information

Material	
	Steel
	galvanized

## Dimensions

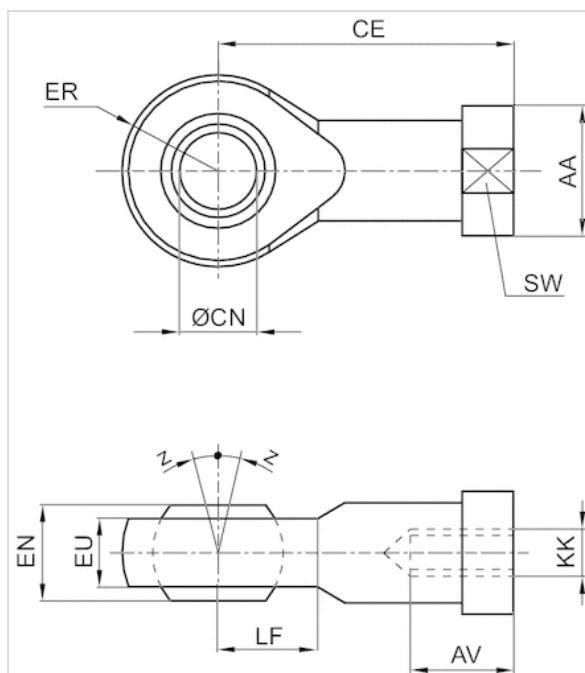

## Dimensions

Part No.	KK	AA	AVmin.	CE	Ø CNH7	EN -0,1	ER	EU max.	LF	SW	Z [°]max.
1822124001	M6	13	9	30	6	9	10	7.5	10	11	4
1822124002	M8	16	12	36	8	12	12	9.5	12	14	4

# Flexible spherical coupling, Series PM5

- to mount on cylinder PRA, TRB, CCL-IS/-IC, CCI, SSI, MNI, KPZ, KHZ, 167, CVI, RPC, RDC, ITS



Weight

See table below

## Technical data

Part No.	Suitable piston rod thread	for
R412007860	M5	KHZ
R412026140	M6x1	CCL-IC, CCI, MNI, KHZ
R412026141	M8x1,25	CCL-IC, CCI, MNI, KHZ
R412026142	M10x1,25	PRA, TRB, CCL-IS, CCL-IC, CCI, SSI, KPZ, 167, CVI, RPC, RDC, KHZ

Part No.	Weight
R412007860	0,02 kg
R412026140	0,02 kg
R412026141	0,05 kg
R412026142	0,21 kg

## Technical information

Material
Steel
galvanized

## Dimensions

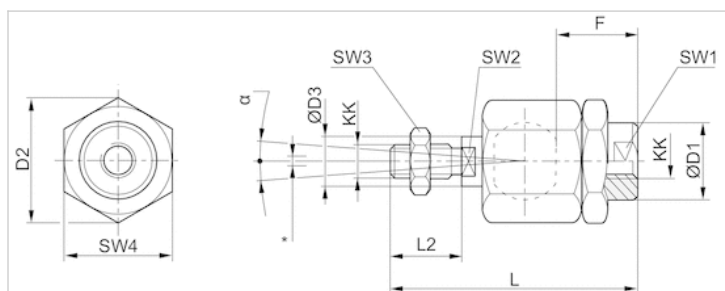

\* Radial joint

## Dimensions

Part No.	KK	Ø D1	D2	Ø D3	F	L ±2	L2	SW1	SW2	SW3	SW4	α [°]	1)	2)
R412007860	M5	8.5	14.8	6	12	38.5	13.5	7	5	8	13	8	0.05-0.2	0-0,5
R412026140	M6x1	8.5	14.5	6	11	36.5	11	7	5	10	13	6	0.05-0.5	0-1,5
R412026141	M8x1,25	12.5	19	8	21	58	21	11	7	13	17	8	0.05-0.5	0-1,5
R412026142	M10x1,25	22	32	14	23	74.5	23	19	12	17	30	8	0.05-0.5	0-2

1) Axial play

2) Radial play

# Male threaded rods

- for series KHZ and SSI with internal thread



Weight

See table below

## Technical data

Part No.	Suitable piston rod thread	Weight
2701412000	M3	0,01 kg
2701420000	M5	0,015 kg
2701432000	M6	0,02 kg
2701450000	M8	0,03 kg
2701463000	M10	0,05 kg

## Technical information

Material
Stainless steel

## Dimensions

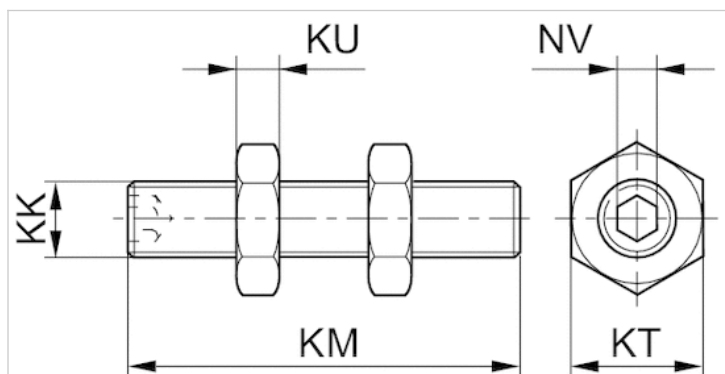

## Dimensions

Part No.	KK	KM	KT	KU	NV
2701412000	M3	20	5.5	1.8	1.5
2701420000	M5	25	8	2.7	2.5
2701432000	M6	30	10	3.2	3
2701450000	M8	35	13	4	4
2701463000	M10	40	16	5	5

# Sensor, Series ST6

- 6 mm T-slot
- with cable
- open cable ends, 3-pin
- ATEX
- UL certification, ATEX
- electronic PNP
- Direct mounting for series PRA, PRE, CCI, KPZ, SSI, GPC, CVI
- Indirect mounting for series TRB, ITS, CCL-IS, MNI, CSL-RD, ICM, KHZ, TRR



**Certificates**

ATEX class G	ATEX, CE declaration of conformity, cULus, RoHS
ATEX class D	II 3G Ex nA IIC T4 Gc X
Ambient temperature min./max.	II 3D Ex tc IIIC T135°C Dc X
Protection class	-20 ... 50 °C
Switching point precision	IP67
Quiescent current (without load)	±0,1 mT
Min./max. DC operating voltage	10 mA
Switching logic	10 ... 30 V DC
LED status display	NO (make contact)
Vibration resistance	Yellow
Shock resistance	10 - 55 Hz, 1 mm
	30 g / 11 ms

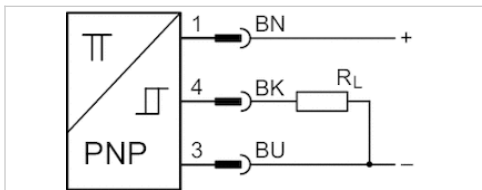

## Technical data

Part No.	for	Type of contact	Cable length L
R412022854	PRA, PRE, CCI, KPZ, SSI, GPC, CVI	electronic PNP	3 m
R412022856	PRA, PRE, CCI, KPZ, SSI, GPC, CVI	electronic PNP	5 m

Part No.	Voltage drop U at I <sub>max</sub>	DC switching current, max.
R412022854	≤ 2,5 V	0,1 A
R412022856	≤ 2,5 V	0,1 A

Part No.	Max. switching frequency
R412022854	1000 Hz
R412022856	1000 Hz

Part No.	Version
R412022854	short circuit resistant, Protected against polarity reversal

Part No.	Version
R412022856	short circuit resistant, Protected against polarity reversal

## Technical information

Material	
Housing	Polyamide
Cable sheath	Polyurethane
Locking screw	Stainless steel

## Dimensions

Fig. 2

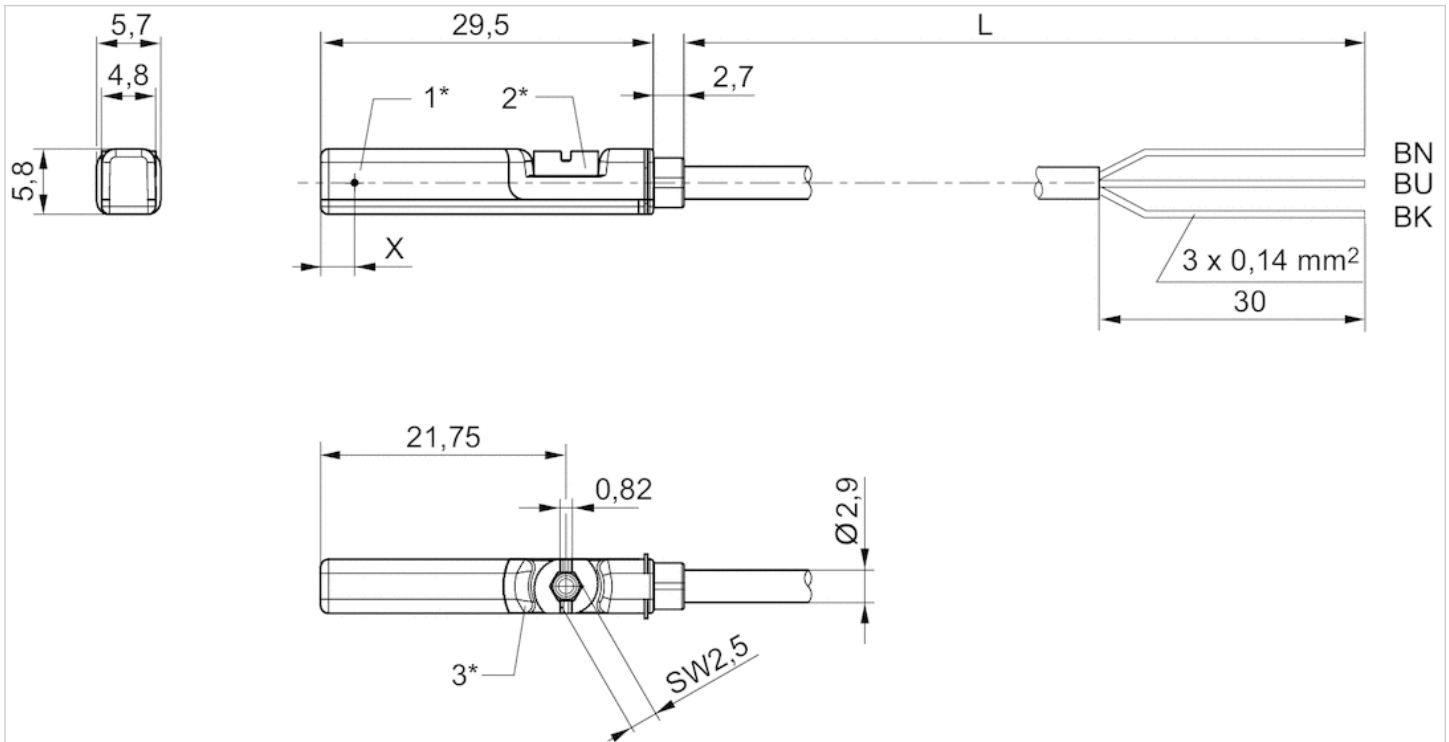

1\* = switching point 2\* = locking screw 3\* = LED window, transparent  
 L = cable length BN = brown, BK = black, BU = blue  
 X = electronic: 11.6 mm

## Sensor, Series ST6









- 6 mm T-slot
- with cable
- open cable ends, 2-pin, open cable ends, 3-pin
- UL certification
- Reed, electronic PNP, electronic NPN
- Direct mounting for series PRA, PRE, CCI, KPZ, SSI, GPC, CVI
- Indirect mounting for series TRB, ITS, CCL-IS, MNI, CSL-RD, ICM, KHZ, TRR



### Certificates

Ambient temperature min./max.	CE declaration of conformity, cULus, RoHS
Protection class	-30 ... 80 °C
Switching point precision	IP65, IP67, IP69K
Nominal current, actuated state	±0,1 mT
Quiescent current (without load)	30 mA
Min./max. DC operating voltage	8 mA
Min./max. AC operating voltage	See table below
Hysteresis	See table below
Switching logic	≥ 0,2 mT
LED status display	NO (make contact)
Vibration resistance	Yellow
Shock resistance	10 - 55 Hz, 1 mm
	30 g / 11 ms

## Technical data

Part No.		for	Type of contact
R412022866		PRA, PRE, CCI, KPZ, SSI, GPC, CVI	Reed
R412022869		PRA, PRE, CCI, KPZ, SSI, GPC, CVI	Reed
R412022870		PRA, PRE, CCI, KPZ, SSI, GPC, CVI	Reed
R412022871		PRA, PRE, CCI, KPZ, SSI, GPC, CVI	Reed
R412022853		PRA, PRE, CCI, KPZ, SSI, GPC, CVI	electronic PNP
R412022855		PRA, PRE, CCI, KPZ, SSI, GPC, CVI	electronic PNP
R412022857		PRA, PRE, CCI, KPZ, SSI, GPC, CVI	electronic PNP
R412022849		PRA, PRE, CCI, KPZ, SSI, GPC, CVI	electronic NPN
R412022850		PRA, PRE, CCI, KPZ, SSI, GPC, CVI	electronic NPN

Part No.	Cable length L	Min./max. DC operating voltage	Min./max. AC operating voltage
R412022866	3 m	10 ... 230 V DC	10 ... 230 V AC
R412022869	3 m	10 ... 30 V DC	10 ... 30 V AC
R412022870	5 m	10 ... 30 V DC	10 ... 30 V AC
R412022871	10 m	10 ... 30 V DC	10 ... 30 V AC
R412022853	3 m	10 ... 30 V DC	-
R412022855	5 m	10 ... 30 V DC	-
R412022857	10 m	10 ... 30 V DC	-
R412022849	3 m	10 ... 30 V DC	-
R412022850	5 m	10 ... 30 V DC	-

Part No.	Voltage drop U at I <sub>max</sub>	DC switching current, max.
R412022866	≤ 3,5 V	0,13 A
R412022869	I*Rs	0,3 A
R412022870	≤ 0,1 V	0,3 A
R412022871	I*Rs	0,3 A
R412022853	≤ 2,5 V	0,13 A
R412022855	≤ 2,5 V	0,13 A
R412022857	≤ 2,5 V	0,13 A
R412022849	≤ 2,5 V	0,13 A
R412022850	≤ 2,5 V	0,13 A

Part No.	AC switching current, max.	Switching capacity
R412022866	0,13 A	Reed, 2-pin: max. 10 W, Reed, 3-pin: max. 6 W
R412022869	0,5 A	Reed, 2-pin: max. 10 W, Reed, 3-pin: max. 6 W
R412022870	0,5 A	Reed, 2-pin: max. 10 W, Reed, 3-pin: max. 6 W
R412022871	0,5 A	Reed, 2-pin: max. 10 W, Reed, 3-pin: max. 6 W
R412022853	-	-
R412022855	-	-
R412022857	-	-
R412022849	-	-

Part No.	AC switching current, max.	Switching capacity
R412022850	-	-

Part No.	Max. switching frequency	Operating current, not switched
R412022866	400 Hz	-
R412022869	400 Hz	-
R412022870	400 Hz	-
R412022871	400 Hz	-
R412022853	1000 Hz	8 mA
R412022855	1000 Hz	8 mA
R412022857	1000 Hz	8 mA
R412022849	1000 Hz	8 mA
R412022850	1000 Hz	8 mA

Part No.	Operating current, switched
R412022866	-
R412022869	-
R412022870	-
R412022871	-
R412022853	30 mA
R412022855	30 mA
R412022857	30 mA
R412022849	30 mA
R412022850	30 mA

Part No.	Version	Fig.	
R412022866	Protected against polarity reversal	Fig. 1	1)
R412022869	Protected against polarity reversal	Fig. 2	2)
R412022870	Protected against polarity reversal	Fig. 2	2)
R412022871	Protected against polarity reversal	Fig. 2	2)
R412022853	short circuit resistant, Protected against polarity reversal	Fig. 2	2)
R412022855	short circuit resistant, Protected against polarity reversal	Fig. 2	2)
R412022857	short circuit resistant, Protected against polarity reversal	Fig. 2	2)
R412022849	short circuit resistant, Protected against polarity reversal	Fig. 2	2)
R412022850	short circuit resistant, Protected against polarity reversal	Fig. 2	2)

1) open cable ends, 2-pin

2) open cable ends, 3-pin

## Technical information

No cULus certification for 230 V variant.

## Technical information

### Material

Housing	Polyamide
Cable sheath	Polyurethane
Locking screw	Stainless steel

Fig. 2

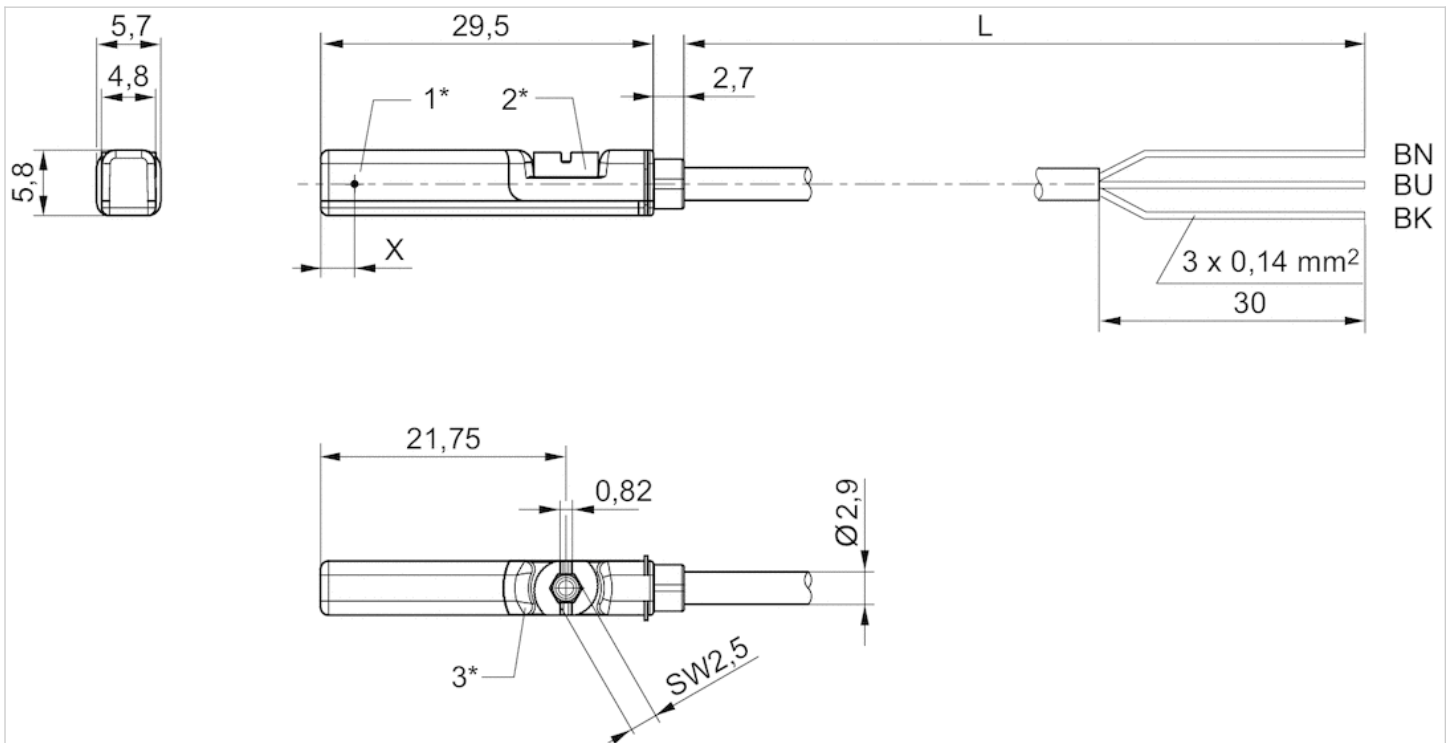

1\* = switching point 2\* = locking screw 3\* = LED window, transparent

L = cable length BN = brown, BK = black, BU = blue

X = electronic: 11.6 mm

## Dimensions

Fig. 1

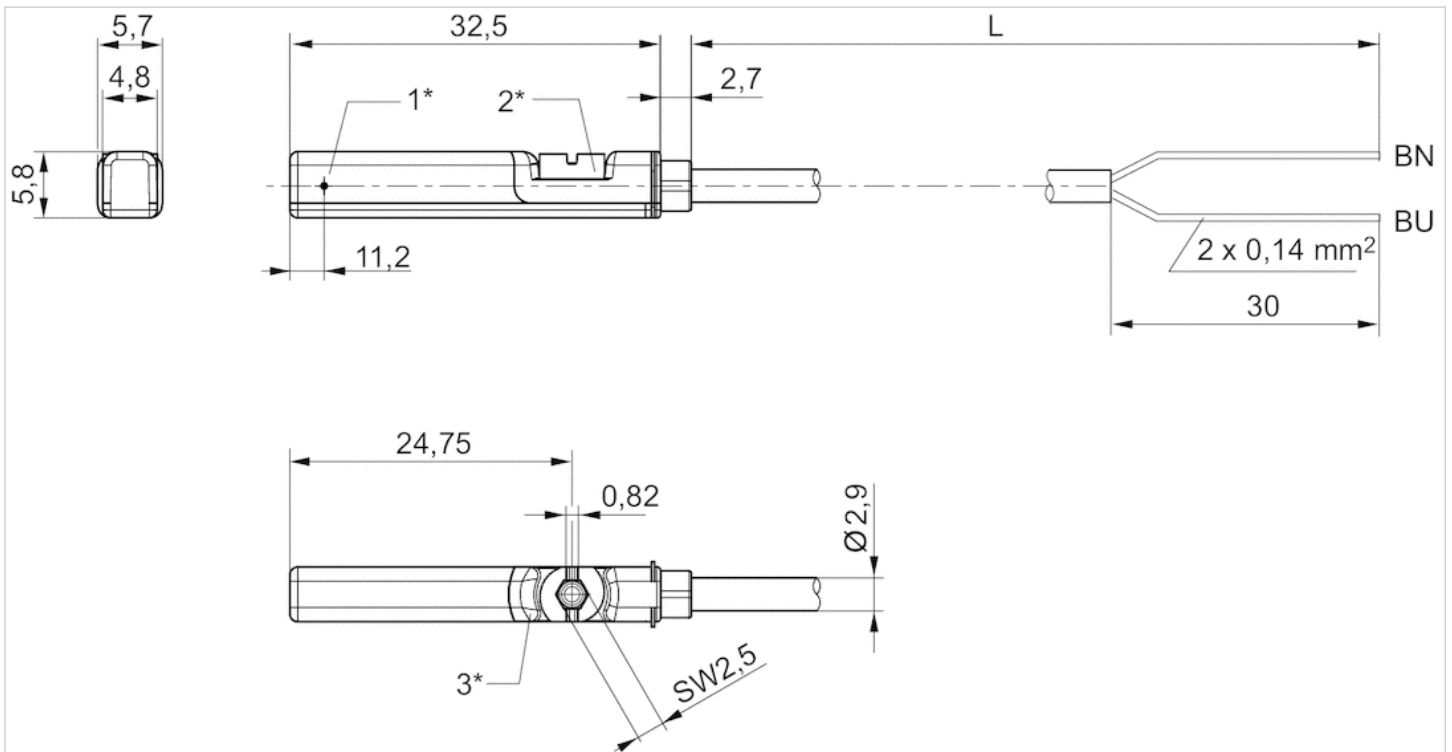

1\* = switching point 2\* = locking screw 3\* = LED window, transparent  
 L = cable length BN=brown, BU=blue





# Sensor, Series ST6

- 6 mm T-slot
- with cable
- Plug, M8, 3-pin
- UL certification
- Reed, electronic PNP, electronic NPN
- Direct mounting for series PRA, PRE, CCI, KPZ, SSI, GPC, CVI
- Indirect mounting for series TRB, ITS, CCL-IS, MNI, CSL-RD, ICM, KHZ, TRR



Certificates	CE declaration of conformity, cULus, RoHS
Ambient temperature min./max.	-30 ... 80 °C
Protection class	IP65, IP67
Switching point precision	±0,1 mT
Nominal current, actuated state	30 mA
Quiescent current (without load)	8 mA
Min./max. DC operating voltage	10 ... 30 V DC
Min./max. AC operating voltage	See table below
Hysteresis	≥ 0,2 mT
Switching logic	NO (make contact)
Switching capacity	Reed, 2-pin: max. 10 W, Reed, 3-pin: max. 6 W
LED status display	Yellow
Vibration resistance	10 - 55 Hz, 1 mm
Shock resistance	30 g / 11 ms

## Technical data

Part No.		for	Type of contact
R412022868		PRA, PRE, CCI, KPZ, SSI, GPC, CVI	Reed
R412022872		PRA, PRE, CCI, KPZ, SSI, GPC, CVI	Reed
R412022858		PRA, PRE, CCI, KPZ, SSI, GPC, CVI	electronic PNP
R412022851		PRA, PRE, CCI, KPZ, SSI, GPC, CVI	electronic NPN

Part No.	Cable length L	Min./max. AC operating voltage	Voltage drop U at I <sub>max</sub>
R412022868	0,3 m	10 ... 30 V AC	≤ 3,5 V
R412022872	0,3 m	10 ... 30 V AC	≤ 0,1 V
R412022858	0,3 m	-	≤ 2,5 V
R412022851	0,3 m	-	≤ 2,5 V

Part No.	DC switching current, max.	AC switching current, max.
R412022868	0,13 A	0,13 A
R412022872	0,3 A	0,5 A
R412022858	0,13 A	-
R412022851	0,13 A	-

Part No.	Max. switching frequency	Operating current, not switched
R412022868	400 Hz	-
R412022872	400 Hz	-
R412022858	1000 Hz	8 mA
R412022851	1000 Hz	8 mA

Part No.	Operating current, switched
R412022868	-
R412022872	-
R412022858	30 mA
R412022851	30 mA

Part No.	Version
R412022868	Protected against polarity reversal
R412022872	Protected against polarity reversal
R412022858	short circuit resistant, Protected against polarity reversal
R412022851	short circuit resistant, Protected against polarity reversal

## Technical information

Material	
Housing	Polyamide
Cable sheath	Polyurethane
Locking screw	Stainless steel

## Dimensions

### Dimensions

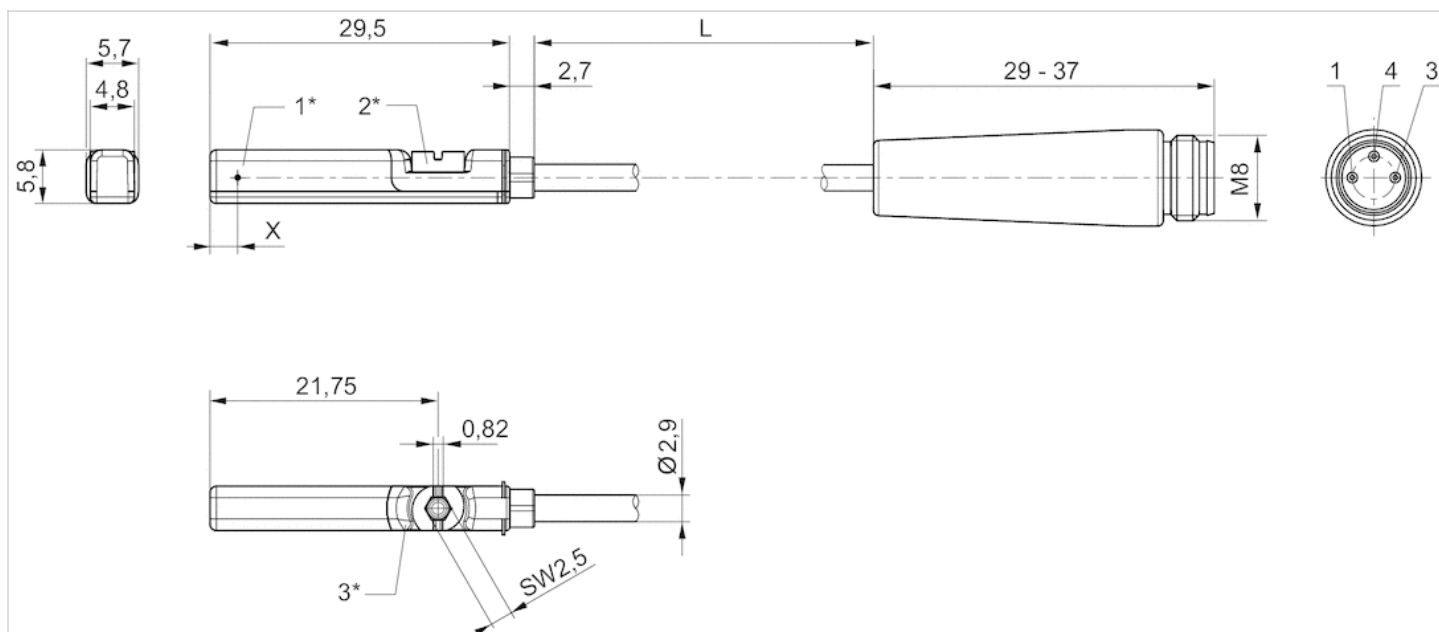

1\* = switching point 2\* = locking screw 3\* = LED window, transparent

L = cable length

X = electronic: 11,6 mm, Reed: 8,3 mm

Pin assignment: 1 = (+) 3 = (-) 4 = (OUT)

# Sensor, Series ST6

- 6 mm T-slot
- with cable
- Plug, M12, 3-pin, with knurled screw
- ATEX
- UL certification, ATEX
- electronic PNP
- Direct mounting for series PRA, PRE, CCI, KPZ, SSI, GPC, CVI
- Indirect mounting for series TRB, ITS, CCL-IS, MNI, CSL-RD, ICM, KHZ, TRR



### Certificates

- ATEX class G
- ATEX class D
- Ambient temperature min./max.
- Protection class
- Switching point precision
- Quiescent current (without load)
- Min./max. DC operating voltage
- Switching logic
- LED status display
- Vibration resistance
- Shock resistance

- ATEX, CE declaration of conformity, cULus, RoHS
- II 3G Ex nA IIC T4 Gc X
- II 3D Ex tc IIIC T135°C Dc X
- 20 ... 50 °C
- IP67
- ±0,1 mT
- 10 mA
- 10 ... 30 V DC
- NO (make contact)
- Yellow, Yellow
- 10 - 55 Hz, 1 mm
- 30 g / 11 ms

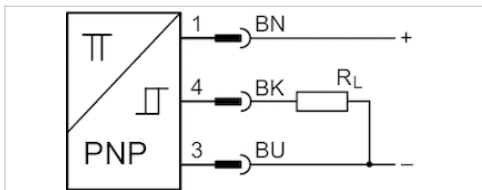

## Technical data

Part No.	for	Type of contact	Cable length L
R412022864	PRA, PRE, CCI, KPZ, SSI, GPC, CVI	electronic PNP	0,3 m

Part No.	Voltage drop U at I <sub>max</sub>	DC switching current, max.
R412022864	≤ 2,5 V	0,1 A

Part No.	Max. switching frequency
R412022864	1000 Hz

Part No.	Version
R412022864	short circuit resistant, Protected against polarity reversal

## Technical information

### Material

Housing	Polyamide
Cable sheath	Polyurethane
Locking screw	Stainless steel

## Dimensions

### Dimensions

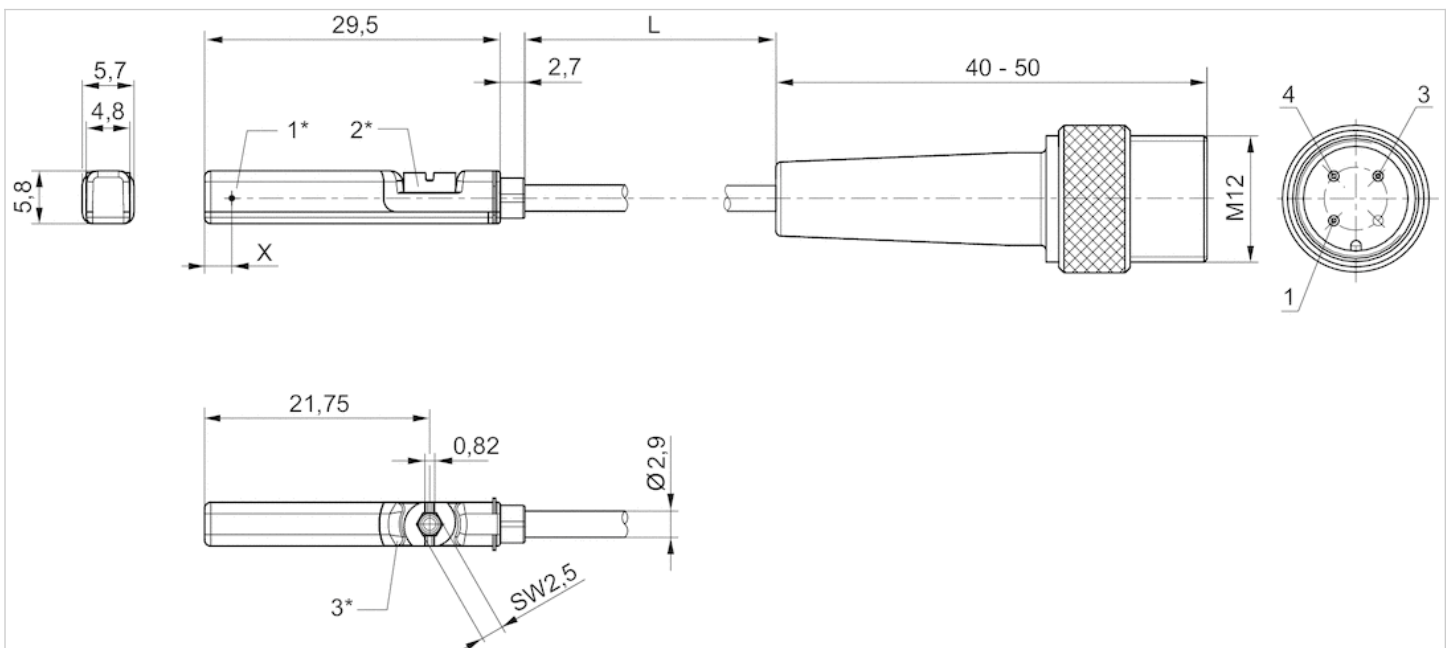

1\* = switching point 2\* = locking screw 3\* = LED window, transparent

L = cable length

X = PNP: 11,6 mm

Pin assignment: 1 = (+) 3 = (-) 4 = (OUT)

# Sensor, Series ST6

- 6 mm T-slot
- with cable
- Plug, M12, 3-pin, with knurled screw
- UL certification
- Reed, electronic PNP
- Direct mounting for series PRA, PRE, CCI, KPZ, SSI, GPC, CVI
- Indirect mounting for series TRB, ITS, CCL-IS, MNI, CSL-RD, ICM, KHZ, TRR







## Certificates

Ambient temperature min./max.	-30 ... 80 °C
Protection class	See table below
Switching point precision	±0,1 mT
Nominal current, actuated state	30 mA
Quiescent current (without load)	8 mA
Min./max. DC operating voltage	10 ... 30 V DC
Min./max. AC operating voltage	See table below
Hysteresis	≥ 0,2 mT
Switching logic	NO (make contact)
Switching capacity	Reed, 3-pin: max. 6 W
LED status display	Yellow
Vibration resistance	10 - 55 Hz, 1 mm
Shock resistance	30 g / 11 ms

CE declaration of conformity, cULus, RoHS

## Technical data

Part No.		for	Type of contact	Cable length L
R412022876		PRA, PRE, CCI, KPZ, SSI, GPC, CVI	Reed	0,3 m
R412022879		PRA, PRE, CCI, KPZ, SSI, GPC, CVI	electronic PNP	0,1 m
R412022863		PRA, PRE, CCI, KPZ, SSI, GPC, CVI	electronic PNP	0,3 m
R412022877		PRA, PRE, CCI, KPZ, SSI, GPC, CVI	electronic PNP	3 m
R412022878		PRA, PRE, CCI, KPZ, SSI, GPC, CVI	electronic PNP	5 m

Part No.	Min./max. AC operating voltage	Voltage drop U at I <sub>max</sub>
R412022876	10 ... 30 V AC	≤ 0,1 V
R412022879	-	≤ 2,5 V
R412022863	-	≤ 2,5 V
R412022877	-	≤ 2,5 V
R412022878	-	≤ 2,5 V

Part No.	DC switching current, max.	AC switching current, max.
R412022876	0,3 A	0,5 A
R412022879	0,13 A	-
R412022863	0,13 A	-
R412022877	0,13 A	-

Part No.	DC switching current, max.	AC switching current, max.
R412022878	0,13 A	-

Part No.	Max. switching frequency	Operating current, not switched
R412022876	400 Hz	-
R412022879	1000 Hz	8 mA
R412022863	1000 Hz	8 mA
R412022877	1000 Hz	8 mA
R412022878	1000 Hz	8 mA

Part No.	Operating current, switched	Protection class
R412022876	-	IP65, IP67
R412022879	30 mA	IP65, IP67
R412022863	30 mA	IP65, IP67, IP69K
R412022877	30 mA	IP65, IP67
R412022878	30 mA	IP65, IP67

Part No.	Version
R412022876	Protected against polarity reversal
R412022879	short circuit resistant, Protected against polarity reversal
R412022863	short circuit resistant, Protected against polarity reversal
R412022877	short circuit resistant, Protected against polarity reversal
R412022878	short circuit resistant, Protected against polarity reversal

## Technical information

Material	
Housing	Polyamide
Cable sheath	Polyurethane
Locking screw	Stainless steel

# Dimensions

## Dimensions

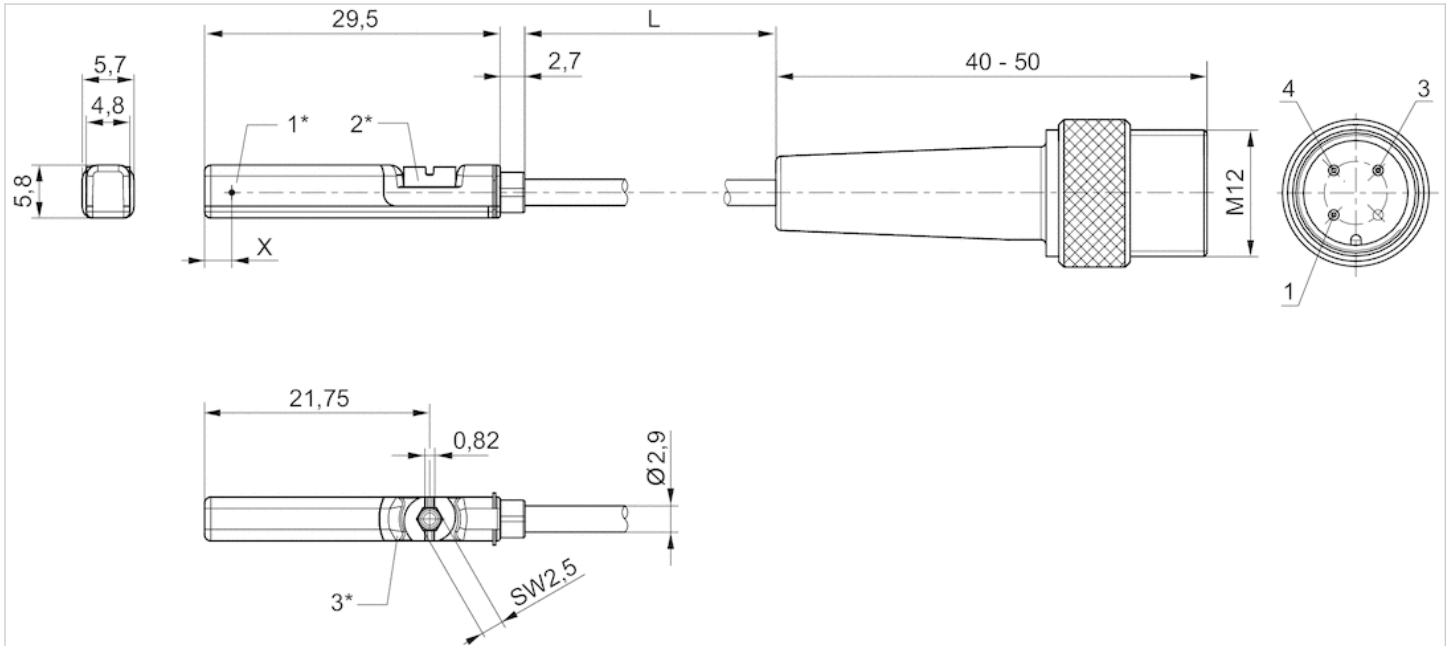

1\* = switching point 2\* = locking screw 3\* = LED window, transparent

L = cable length

X = PNP: 11,6 mm

Pin assignment: 1 = (+) 3 = (-) 4 = (OUT)

# Sensor, Series ST6

- 6 mm T-slot
- with cable
- Plug, M8, 3-pin, with knurled screw
- ATEX
- UL certification, ATEX
- electronic PNP
- Direct mounting for series PRA, PRE, CCI, KPZ, SSI, GPC, CVI
- Indirect mounting for series TRB, ITS, CCL-IS, MNI, CSL-RD, ICM, KHZ, TRR



### Certificates

ATEX class G	ATEX, CE declaration of conformity, cULus, RoHS
ATEX class D	II 3G Ex nA IIC T4 Gc X
Ambient temperature min./max.	II 3D Ex tc IIIC T135°C Dc X
Protection class	-20 ... 50 °C
Switching point precision	IP65, IP67
Quiescent current (without load)	±0,1 mT
Min./max. DC operating voltage	10 mA
Switching logic	10 ... 30 V DC
LED status display	NO (make contact)
Vibration resistance	Yellow, Yellow
Shock resistance	10 - 55 Hz, 1 mm
	30 g / 11 ms

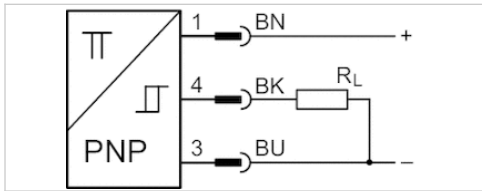

## Technical data

Part No.	for	Type of contact	Cable length L
R412022860	PRA, PRE, CCI, KPZ, SSI, GPC, CVI	electronic PNP	0,3 m

Part No.	Voltage drop U at I <sub>max</sub>	DC switching current, max.
R412022860	≤ 2,5 V	0,1 A

Part No.	Max. switching frequency
R412022860	1000 Hz

Part No.	Version
R412022860	short circuit resistant, Protected against polarity reversal

## Technical information

### Material

Housing	Polyamide
Cable sheath	Polyurethane
Locking screw	Stainless steel

## Dimensions

### Dimensions

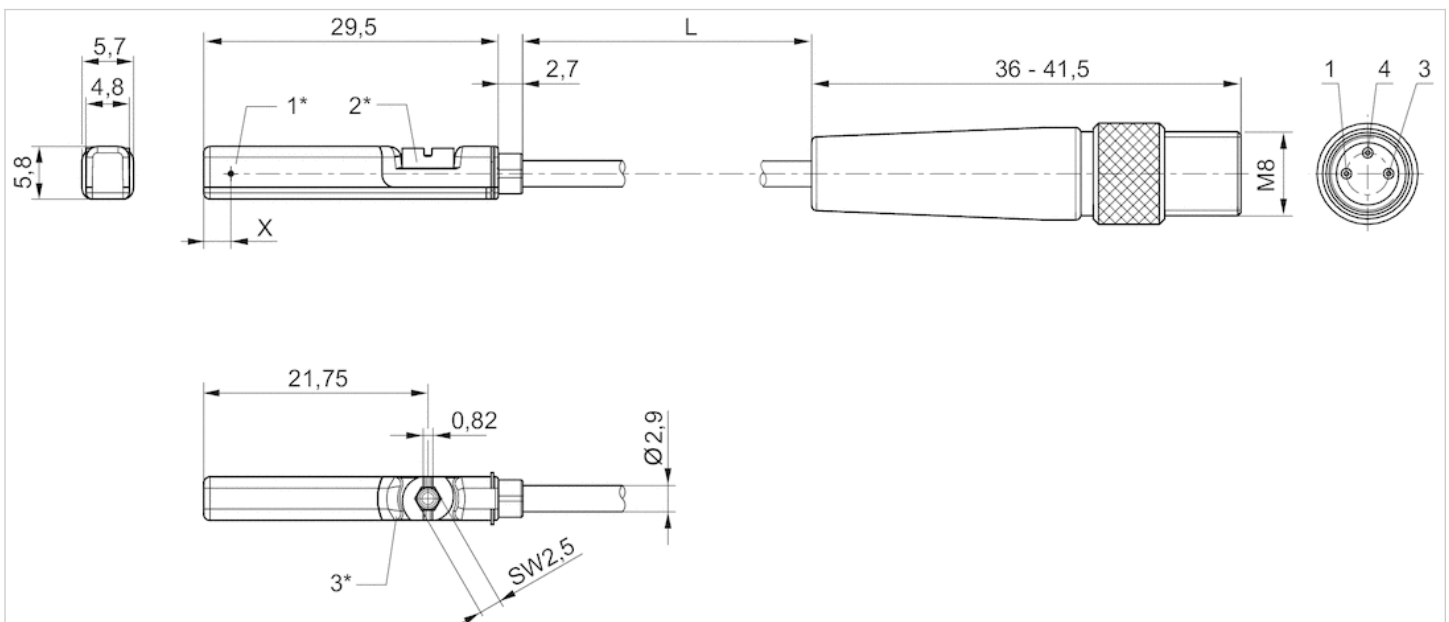

1\* = switching point 2\* = locking screw 3\* = LED window, transparent

L = cable length

X = electronic: 11,6 mm, Reed: 8,3 mm

Pin assignment: 1 = (+) 3 = (-) 4 = (OUT)







# Sensor, Series ST6

- 6 mm T-slot
- with cable
- Plug, M8, 3-pin, with knurled screw
- UL certification
- Reed, electronic PNP, electronic NPN
- Direct mounting for series PRA, PRE, CCI, KPZ, SSI, GPC, CVI
- Indirect mounting for series TRB, ITS, CCL-IS, MNI, CSL-RD, ICM, KHZ, TRR



Certificates	CE declaration of conformity, cULus, RoHS
Ambient temperature min./max.	-30 ... 80 °C
Protection class	IP65, IP67
Switching point precision	±0,1 mT
Nominal current, actuated state	30 mA
Quiescent current (without load)	8 mA
Min./max. DC operating voltage	10 ... 30 V DC
Min./max. AC operating voltage	See table below
Hysteresis	≥ 0,2 mT
Switching logic	NO (make contact)
Switching capacity	Reed, 3-pin: max. 6 W
LED status display	Yellow
Vibration resistance	10 - 55 Hz, 1 mm
Shock resistance	30 g / 11 ms

## Technical data

Part No.		for	Type of contact
R412022873		PRA, PRE, CCI, KPZ, SSI, GPC, CVI	Reed
R412022875		PRA, PRE, CCI, KPZ, SSI, GPC, CVI	Reed
R412022874		PRA, PRE, CCI, KPZ, SSI, GPC, CVI	Reed
R412022859		PRA, PRE, CCI, KPZ, SSI, GPC, CVI	electronic PNP
R412022862		PRA, PRE, CCI, KPZ, SSI, GPC, CVI	electronic PNP
R412022861		PRA, PRE, CCI, KPZ, SSI, GPC, CVI	electronic PNP
R412022852		PRA, PRE, CCI, KPZ, SSI, GPC, CVI	electronic NPN

Part No.	Cable sheath	Cable length L	Min./max. AC operating voltage
R412022873	Polyurethane	0,3 m	10 ... 30 V AC
R412022875	Polyvinyl chloride	0,3 m	10 ... 30 V AC
R412022874	Polyurethane	0,5 m	10 ... 30 V AC
R412022859	Polyurethane	0,3 m	-
R412022862	Polyvinyl chloride	0,3 m	-
R412022861	Polyurethane	0,5 m	-
R412022852	Polyurethane	0,3 m	-

Part No.	Voltage drop U at I <sub>max</sub>	DC switching current, max.
R412022873	I*Rs	0,3 A
R412022875	I*Rs	0,3 A
R412022874	I*Rs	0,3 A
R412022859	≤ 2,5 V	0,13 A
R412022862	≤ 2,5 V	0,13 A
R412022861	≤ 2,5 V	0,13 A
R412022852	≤ 2,5 V	0,13 A

Part No.	AC switching current, max.	Max. switching frequency
R412022873	0,5 A	400 Hz
R412022875	0,5 A	400 Hz
R412022874	0,5 A	400 Hz
R412022859	-	1000 Hz
R412022862	-	1000 Hz
R412022861	-	1000 Hz
R412022852	-	1000 Hz

Part No.	Operating current, not switched	Operating current, switched
R412022873	-	-
R412022875	-	-
R412022874	-	-
R412022859	8 mA	30 mA
R412022862	8 mA	30 mA
R412022861	8 mA	30 mA
R412022852	8 mA	30 mA

Part No.	Version
R412022873	Protected against polarity reversal
R412022875	Protected against polarity reversal
R412022874	Protected against polarity reversal
R412022859	short circuit resistant, Protected against polarity reversal
R412022862	short circuit resistant, Protected against polarity reversal
R412022861	short circuit resistant, Protected against polarity reversal
R412022852	short circuit resistant, Protected against polarity reversal

## Technical information

Material	
Housing	Polyamide
Cable sheath	Polyurethane, Polyvinyl chloride
Locking screw	Stainless steel

## Dimensions

### Dimensions

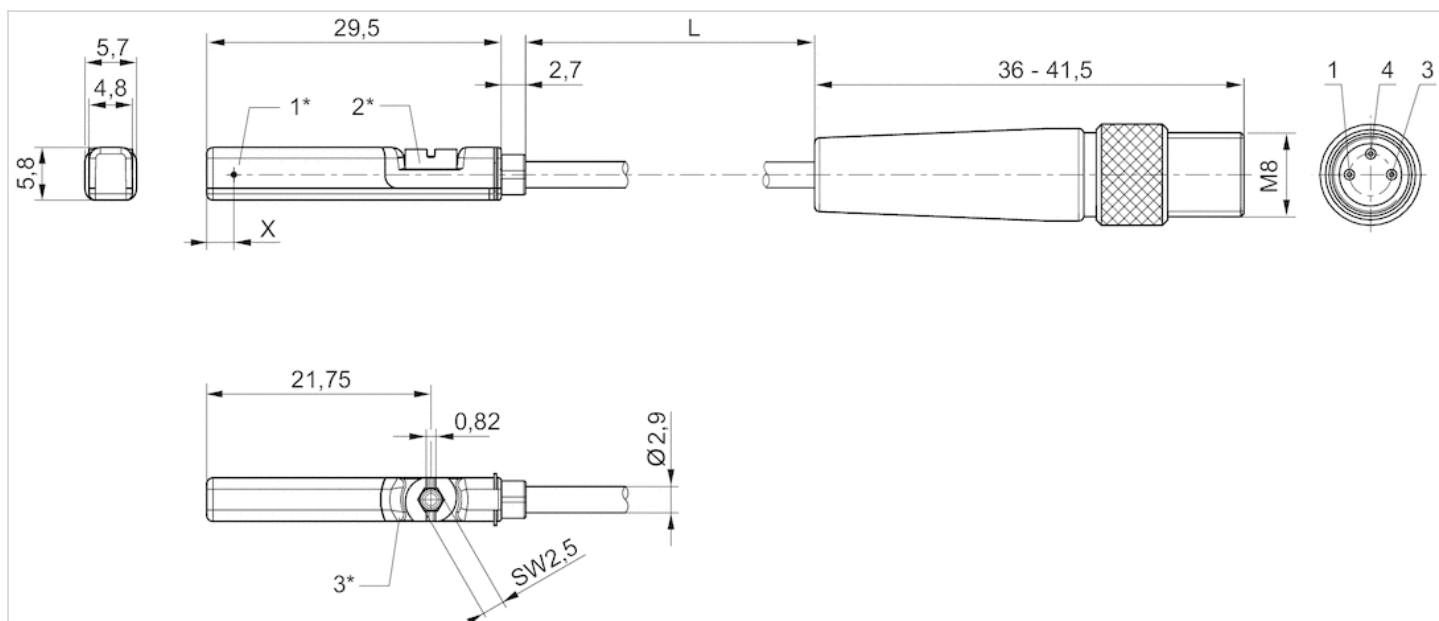

1\* = switching point 2\* = locking screw 3\* = LED window, transparent

L = cable length

X = electronic: 11,6 mm, Reed: 8,3 mm

Pin assignment: 1 = (+) 3 = (-) 4 = (OUT)









## Sensor, Series ST9

- 9 mm groove
- with cable
- without wire end ferrule, tin-plated, 2-pin, without wire end ferrule, tin-plated, 3-pin
- With stretched impulse
- With stretched impulse
- Reed, electronic PNP
- Direct mounting for series KHZ



Ambient temperature min./max.	See table below
Protection class	IP67, IP65
Switching point precision	±0,1 mT
Nominal current, actuated state	7 mA
Quiescent current (without load)	3 mA
Min./max. DC operating voltage	See table below
Min./max. AC operating voltage	See table below
LED status display	See table below
Vibration resistance	60 g (50 ... 2000 Hz)
Shock resistance	100 g / 11 ms

## Technical data

Part No.		for	Type of contact	Cable sheath	Cable length L
0830100320		KHZ	Reed	Polyvinyl chloride	3 m
0830100380		KHZ	Reed	Polyvinyl chloride	3 m
0830100381		KHZ	Reed	Polyvinyl chloride	5 m
0830100382		KHZ	Reed	Polyurethane	3 m
0830100390		KHZ	Reed	Polyurethane	3 m
0830100396		KHZ	Reed	Polyurethane	5 m
0830100385		KHZ	electronic PNP	Polyvinyl chloride	3 m
0830100386		KHZ	electronic PNP	Polyvinyl chloride	5 m
0830100387		KHZ	electronic PNP	Polyurethane	3 m

Part No.	Min./max. DC operating voltage	Min./max. AC operating voltage
0830100320	0 ... 24 V DC	0 ... 24 V AC
0830100380	12 ... 24 V DC	12 ... 24 V AC
0830100381	12 ... 24 V DC	12 ... 24 V AC
0830100382	12 ... 24 V DC	12 ... 24 V AC
0830100390	12 ... 24 V DC	12 ... 24 V AC
0830100396	12 ... 24 V DC	12 ... 24 V AC
0830100385	12 ... 36 V DC	-
0830100386	12 ... 36 V DC	-
0830100387	12 ... 36 V DC	-

Part No.	Voltage drop U at I <sub>max</sub>	DC switching current, max.
0830100320	I*Rs	0,13 A
0830100380	2,1 V + I*Rs	0,13 A
0830100381	2,1 V + I*Rs	0,13 A
0830100382	2,1 V + I*Rs	0,13 A
0830100390	I*Rs	0,13 A
0830100396	I*Rs	0,13 A
0830100385	≤ 2,0 V	0,2 A
0830100386	≤ 2,0 V	0,2 A
0830100387	≤ 2,0 V	0,2 A

Part No.	AC switching current, max.	Ambient temperature min./max.	Switching capacity
0830100320	0,2 A	-20 ... 80 °C	3 W / 5 VA
0830100380	0,2 A	-20 ... 80 °C	3 W / 5 VA
0830100381	0,2 A	-20 ... 80 °C	3 W / 5 VA
0830100382	0,2 A	-20 ... 80 °C	3 W / 5 VA
0830100390	0,2 A	-20 ... 80 °C	3 W / 5 VA
0830100396	0,2 A	-20 ... 80 °C	3 W / 5 VA
0830100385	-	-10 ... 70 °C	-
0830100386	-	-10 ... 70 °C	-

Part No.	AC switching current, max.	Ambient temperature min./max.	Switching capacity
0830100387	-	-10 ... 70 °C	-

Part No.	Protective resistor for reed	Max. switching frequency
0830100320	1,3 Ω	-
0830100380	1,3 Ω	-
0830100381	1,3 Ω	-
0830100382	1,3 Ω	-
0830100390	1,3 Ω	-
0830100396	1,3 Ω	-
0830100385	-	2000 Hz
0830100386	-	2000 Hz
0830100387	-	2000 Hz

Part No.	Operating current, not switched	Operating current, switched	LED status display
0830100320	-	-	-
0830100380	-	-	Yellow
0830100381	-	-	Yellow
0830100382	-	-	Yellow
0830100390	-	-	Yellow
0830100396	-	-	Yellow
0830100385	3 mA	7 mA	Yellow
0830100386	3 mA	7 mA	Yellow
0830100387	3 mA	7 mA	Yellow

Part No.	Version
0830100320	Protected against polarity reversal
0830100380	Protected against polarity reversal
0830100381	Protected against polarity reversal
0830100382	Protected against polarity reversal
0830100390	Protected against polarity reversal
0830100396	Protected against polarity reversal
0830100385	short circuit resistant, Protected against polarity reversal
0830100386	short circuit resistant, Protected against polarity reversal
0830100387	short circuit resistant, Protected against polarity reversal

Part No.	Switch signal	
0830100320	-	1)
0830100380	-	1)
0830100381	-	1)
0830100382	-	1)
0830100390	-	2)
0830100396	-	2)
0830100385	With stretched impulse	2)

Part No.	Switch signal	
0830100386	With stretched impulse	2)
0830100387	With stretched impulse	2)

1) without wire end ferrule, tin-plated, 2-pin

2) without wire end ferrule, tin-plated, 3-pin

## Technical information

If reed sensors are used, we recommend using a short-circuit protective device (SCPD).

## Technical information

### Material

Housing	epoxy resin
Cable sheath	Polyvinyl chloride, Polyurethane

## Dimensions

### Dimensions

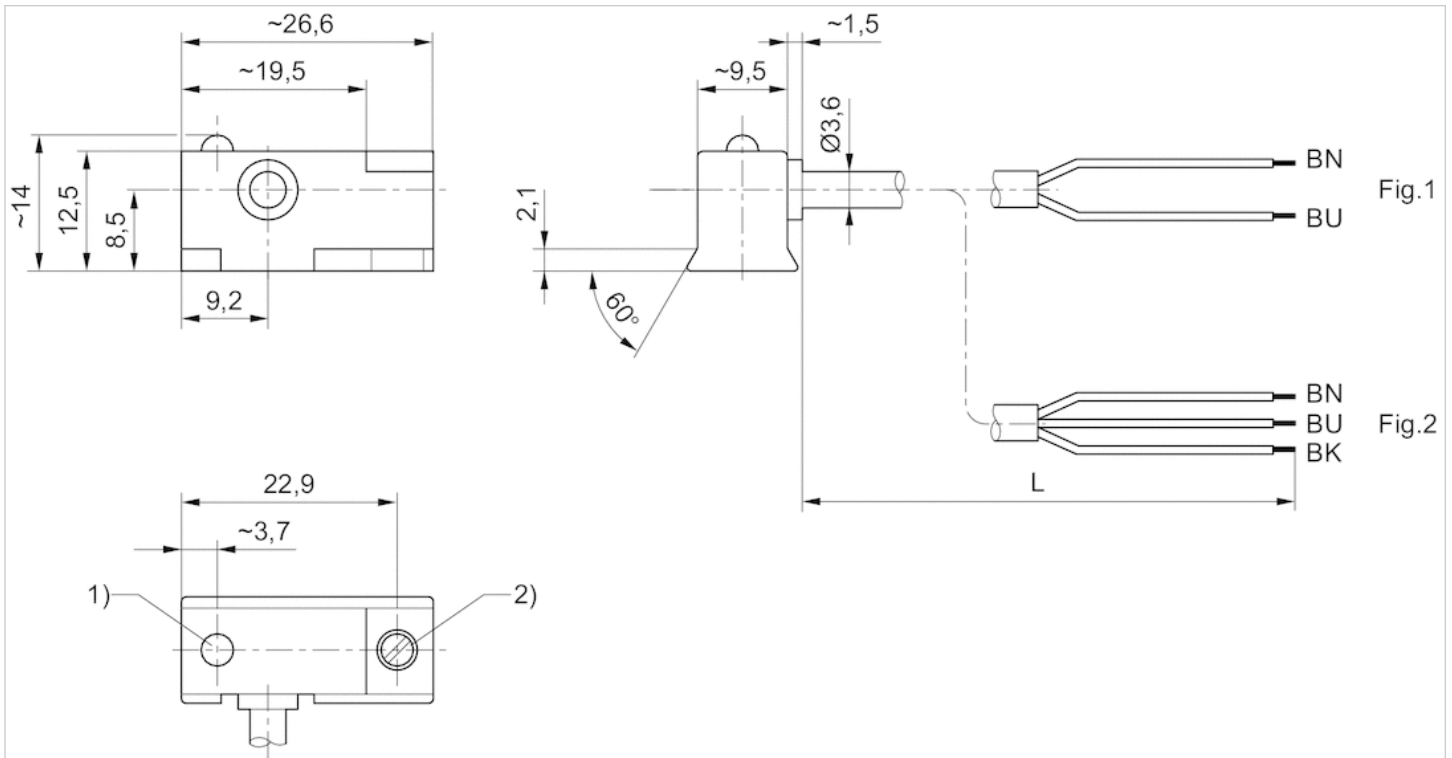

1) LED

2) Clamping screw

L = cable length

BN = brown BK = black BU = blue



# Sensor, Series ST9

- 9 mm groove
- Plug, M8, 3-pin
- Reed, electronic PNP
- Direct mounting for series KHZ



Ambient temperature min./max.	See table below
Protection class	IP67, IP65
Switching point precision	±0,1 mT
Nominal current, actuated state	7 mA
Quiescent current (without load)	3 mA
Min./max. DC operating voltage	See table below
Min./max. AC operating voltage	See table below
LED status display	See table below
Vibration resistance	60 g (50 ... 2000 Hz)
Shock resistance	100 g / 11 ms

## Technical data

Part No.		for	Type of contact	Min./max. DC operating voltage
0830100486		KHZ	Reed	10 ... 30 V DC
0830100487		KHZ	electronic PNP	12 ... 36 V DC

Part No.	Min./max. AC operating voltage	Voltage drop U at I <sub>max</sub>
0830100486	10 ... 30 V AC	I*Rs
0830100487	-	≤ 2,0 V

Part No.	DC switching current, max.	AC switching current, max.
0830100486	0,13 A	0,2 A
0830100487	0,2 A	-

Part No.	Ambient temperature min./max.	Switching capacity	Protective resistor for reed
0830100486	-20 ... 80 °C	3 W / 5 VA	27 Ω
0830100487	-10 ... 70 °C	-	-

Part No.	Max. switching frequency	Operating current, not switched	LED status display
0830100486	-	-	Yellow
0830100487	2000 Hz	3 mA	Yellow, Yellow

Part No.	Version

Part No.	Version
0830100486	Protected against polarity reversal
0830100487	Protected against polarity reversal, short circuit resistant

## Technical information

If reed sensors are used, we recommend using a short-circuit protective device (SCPD).

## Technical information

Material	
Housing	Polyamide

## Dimensions

### Dimensions

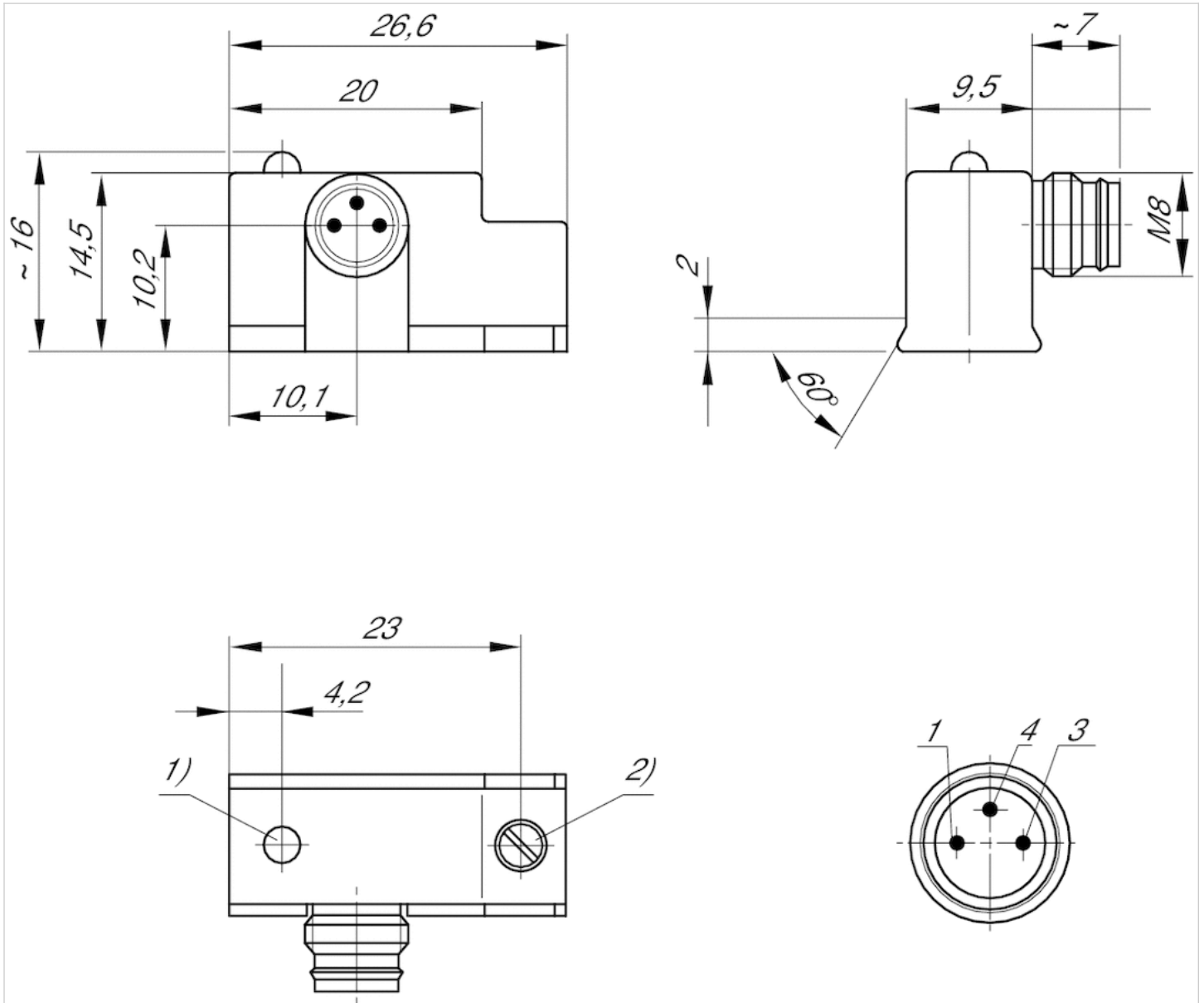

1) LED

2) Clamping screw

M8: combination plug can be combined with valve plug connectors Ø6.5 mm and M8.

Pin assignments: 1 = (+), 3 = (-), 4 = (OUT), EN 60947-5-2:1998

# Sensor, Series SN3

- welding-proof
- Plug, M12, 3-pin
- welding-proof
- electronic PNP
- Indirect mounting for series PRA, PRE, CCI, KPZ, KHZ, FLT, GPC, CVI



Ambient temperature min./max.	-25 ... 70 °C
Protection class	IP67, IP65
Switching point precision	±0,1 mT
Nominal current, actuated state	≤ 10 mA
Quiescent current (without load)	≤ 5 mA
Min./max. DC operating voltage	10 V DC
LED status display	Yellow
Vibration resistance	55 Hz, 1 mm
Shock resistance	30 g / 11 ms

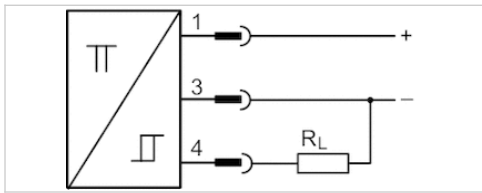

## Technical data

Part No.	Type of contact	Voltage drop U at I <sub>max</sub>	DC switching current, max.
0830100438	electronic PNP	≤ 1,8 V	0,2 A

Part No.	Max. switching frequency
0830100438	20 Hz

Part No.	Version	welding-proof
0830100438	short circuit resistant, Protected against polarity reversal	welding-proof

## Technical information

Material	
Housing	Polyamide

Dimensions

Dimensions

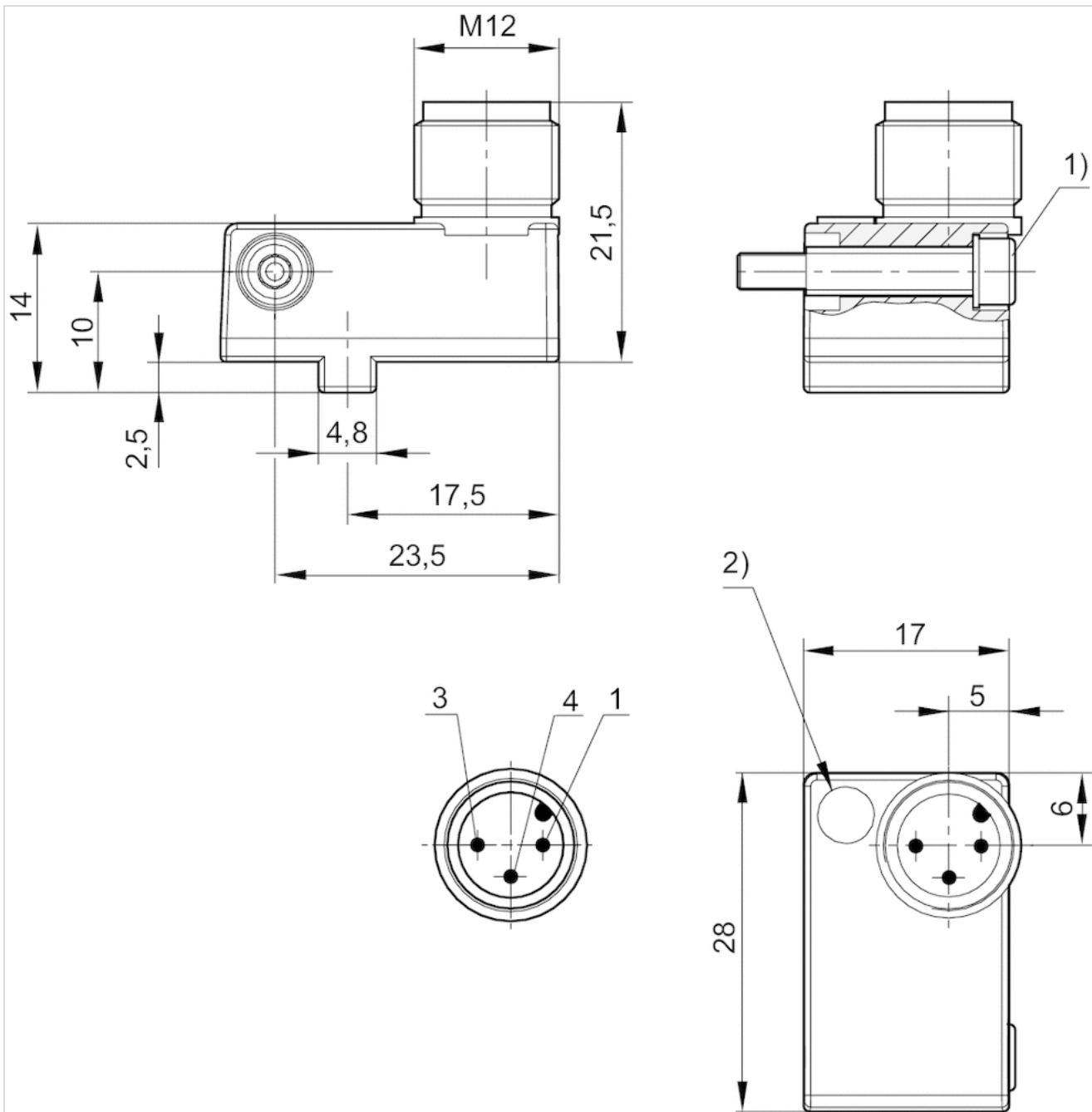

1) Clamping screw

2) LED

Pin assignments: 1 = (+), 3 = (-), 4 = (OUT), EN 60947-5-2:1998

# Sensor mounting, Series CB1

- for series SN3

- to mount on cylinder PRA, KPZ, GPC, CCI, KHZ



Weight

0,007 kg

## Technical data

Part No.	for series
1827020386	SN3

## Technical information

Material
Aluminum

Dimensions

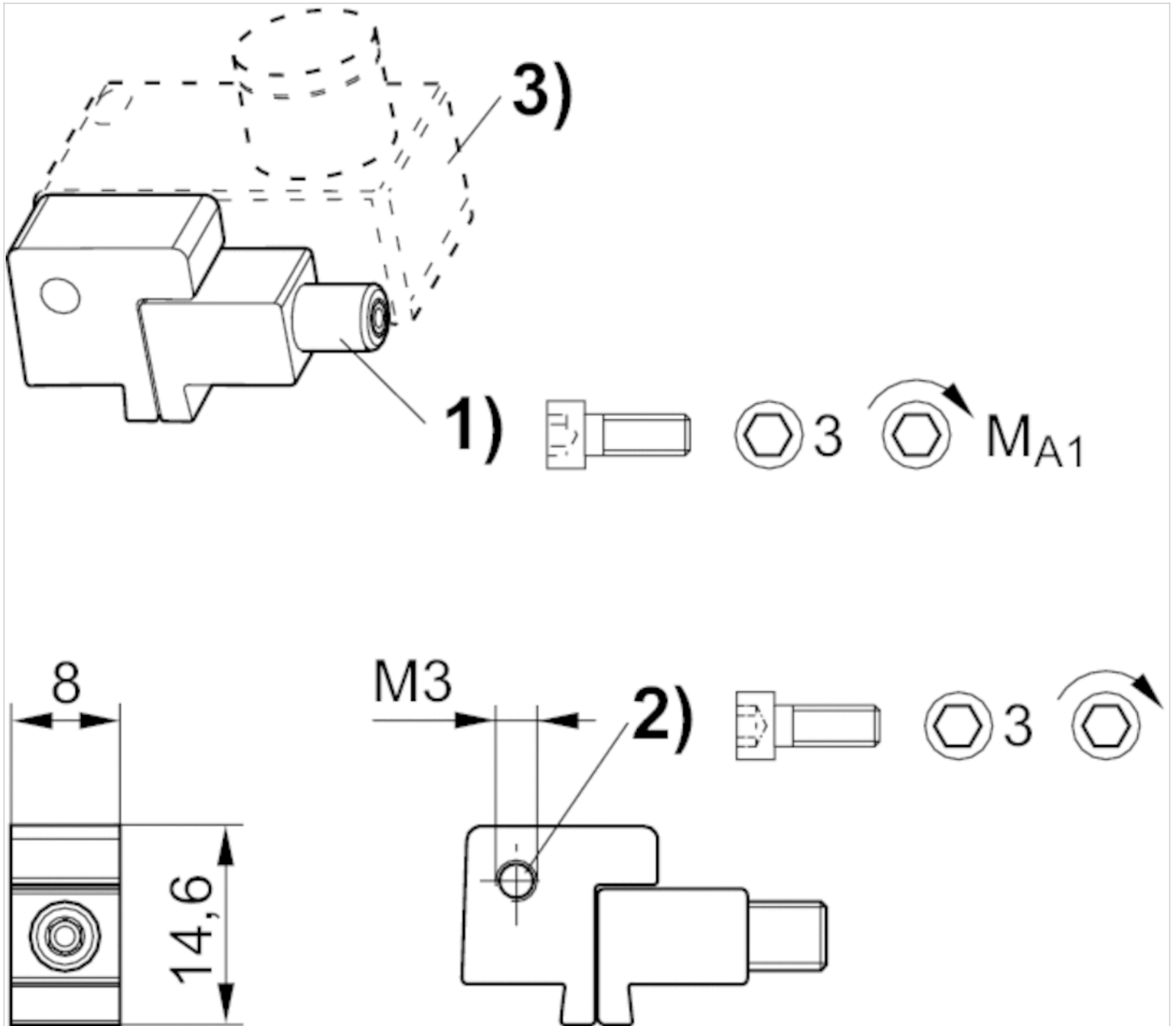

1) Clamping screw 2) Mounting screw for sensor 3) Sensor

Dimensions

Part No.	1)	MA1 [Nm]
1827020386	M3x25	1,8 +0,4

# Sensor mounting, Series CB1

- for series ST6
- to mount on cylinder KHZ



Weight

0,034 kg

## Technical data

Part No.	for series
R422100250	ST6

Scope of delivery: incl. threaded pin

## Technical information

Material
Aluminum, anodized

## Dimensions

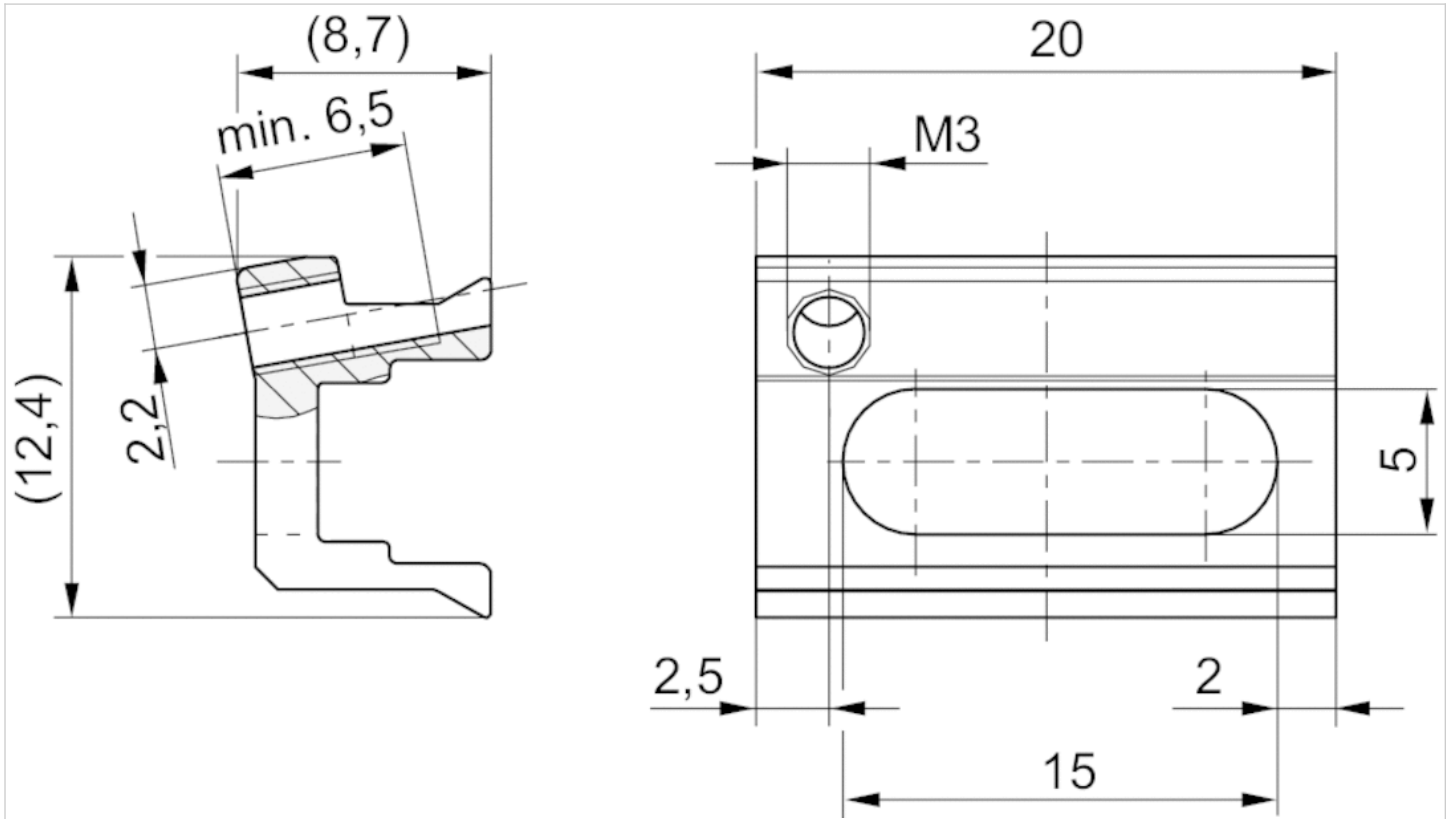

## Dimensions

Part No.

R422100250

Scope of delivery: incl. threaded pin

# Round plug connector, Series CON-RD

- Socket, M8x1, 3-pin, A-coded, angled, 90°
- UL (Underwriters Laboratories)
- unshielded



Connection type	Soldering
Ambient temperature min./max.	-40 ... 85 °C
Operational voltage	48 V, AC/DC
Protection class	IP67
Weight	0,01 kg

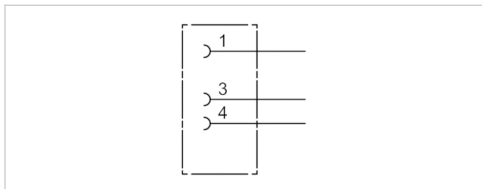

## Technical data

Part No.	Max. current	Contact assignment	suitable cable-Ø min./max
1834484174	4 A	3	3,5 / 5 mm

## Technical information

The specified protection class is only valid in assembled and tested state.

## Technical information

Material	
Housing	Polyamide

## Dimensions

### Dimensions

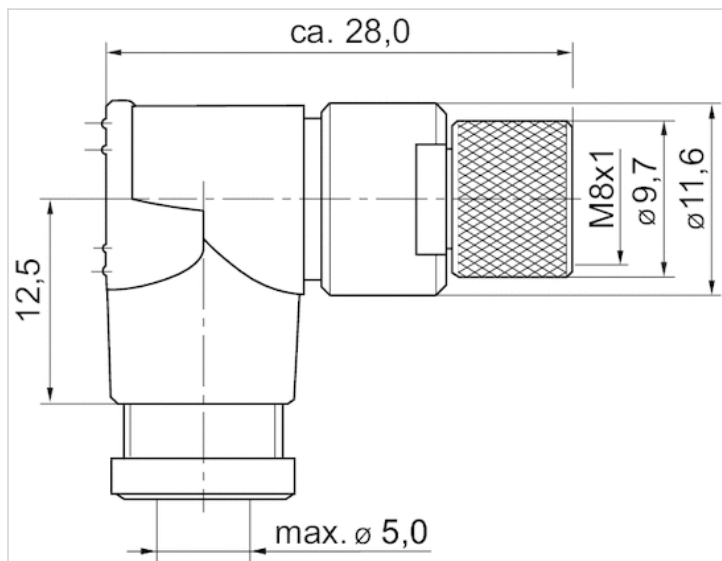

## Pin assignments

### Pin assignment socket

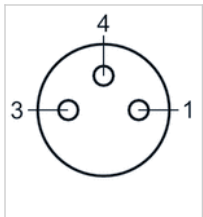

# Round plug connector, Series CON-RD

- Socket, M8x1, 3-pin, A-coded, straight, 180°
- UL (Underwriters Laboratories)
- unshielded



Connection type	Soldering
Ambient temperature min./max.	-25 ... 80 °C
Operational voltage	48 V, AC/DC
Protection class	IP67
Weight	0,009 kg

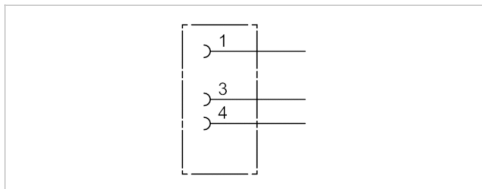

## Technical data

Part No.	Max. current	suitable cable-Ø min./max
1834484173	4 A	3,5 mm

## Technical information

The specified protection class is only valid in assembled and tested state.

## Technical information

Material	
Housing	Polyamide

## Dimensions

### Dimensions

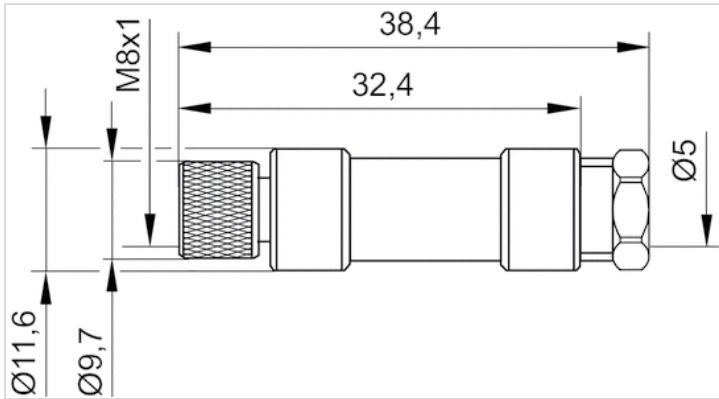

## Pin assignments

### Pin assignment socket

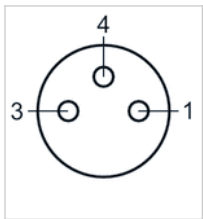

# Round plug connector, Series CON-RD

- Socket, M8x1, 3-pin, A-coded, straight, 180°
- open cable ends
- with cable
- UL (Underwriters Laboratories)
- unshielded

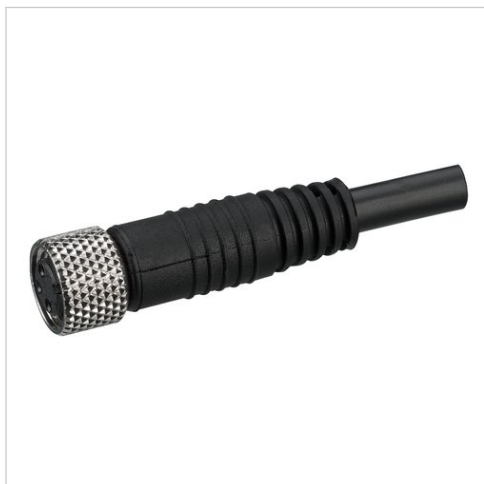

Ambient temperature min./max.	-25 ... 85 °C
Operational voltage	48 V, AC/DC
Protection class	IP67
Wire cross-section	0,24 mm <sup>2</sup>
Weight	See table below

## Technical data

Part No.	Max. current	Number of wires	Cable-Ø	Cable length	Certification	Weight
1834484166	4 A	3	4,5 mm	3 m	UL (Underwriters Laboratories)	0,087 kg
1834484168	4 A	3	4,5 mm	5 m	UL (Underwriters Laboratories)	0,141 kg
1834484247	4 A	3	4,5 mm	10 m	UL (Underwriters Laboratories)	0,277 kg

## Technical information

The specified protection class is only valid in assembled and tested state.

## Technical information

Material	
Housing	Polyurethane
Cable sheath	Polyurethane

## Dimensions

### Dimensions

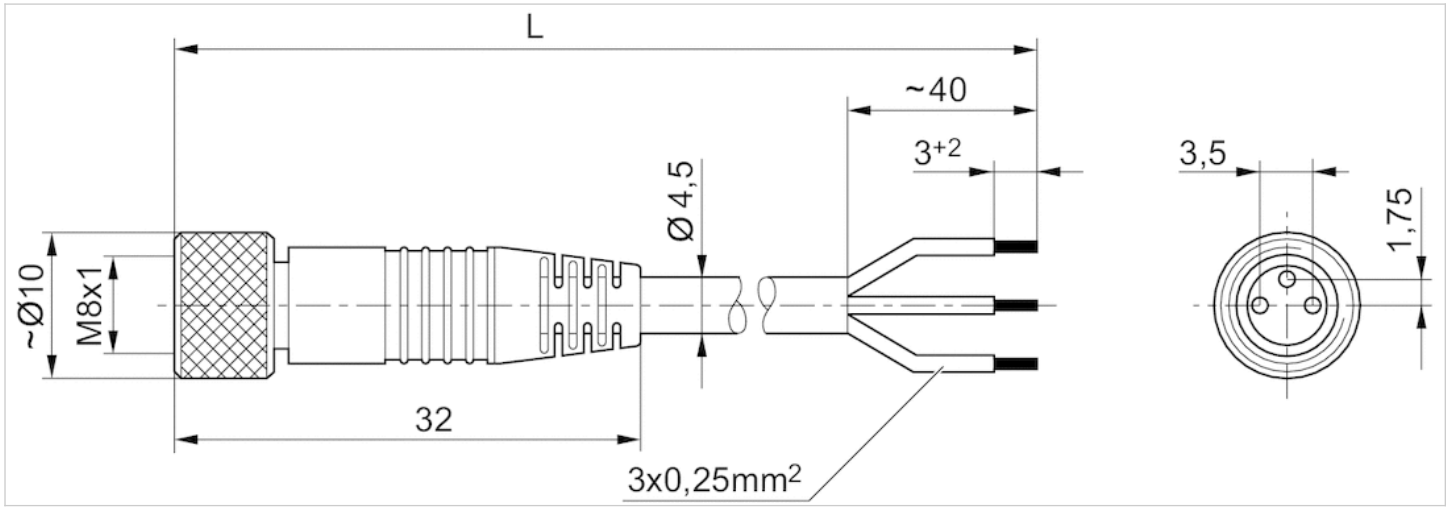

L = length

## Pin assignments

### Pin assignment socket

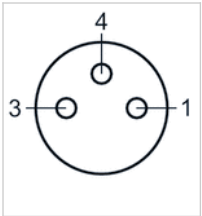

(1) BN=brown(3) BU=blue(4) BK=black

# Round plug connector, Series CON-RD

- Socket, M8x1, 3-pin, A-coded, angled, 90°
- open cable ends
- with cable
- unshielded



Ambient temperature min./max.	-40 ... 85 °C
Operational voltage	48 V, AC/DC
Protection class	IP67
Wire cross-section	0,24 mm <sup>2</sup>
Weight	See table below

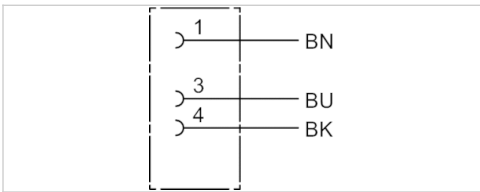

## Technical data

Part No.	Max. current	Number of wires	Cable-Ø	Cable length	Weight
1834484167	4 A	3	4,5 mm	3 m	0,087 kg
1834484169	4 A	3	4,5 mm	5 m	0,139 kg
1834484248	4 A	3	4,5 mm	10 m	0,279 kg

## Technical information

The specified protection class is only valid in assembled and tested state.

## Technical information

Material	
Housing	Polyurethane
Cable sheath	Polyurethane

## Dimensions

### Dimensions

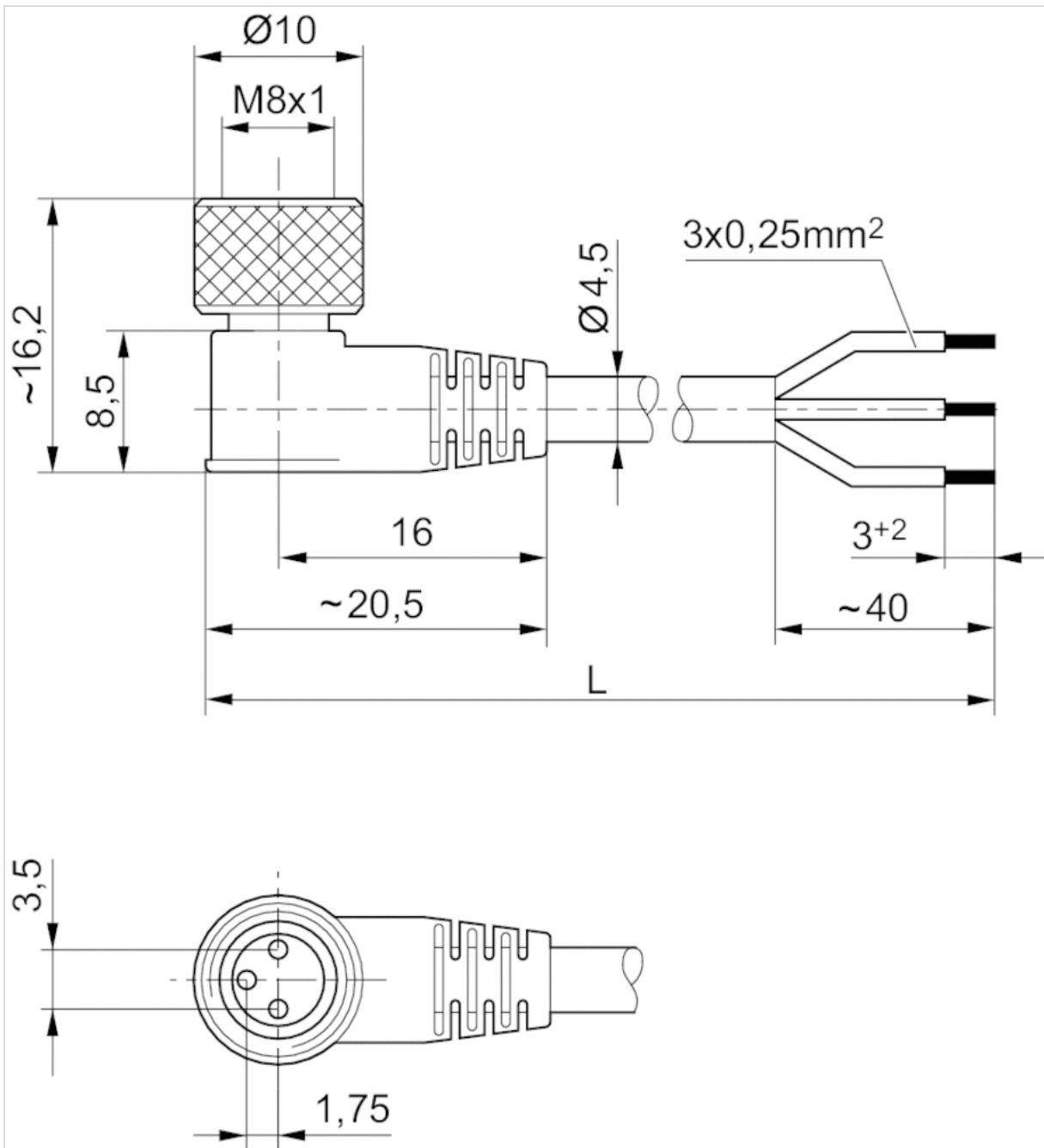

L = length

## Pin assignments

### Pin assignment socket

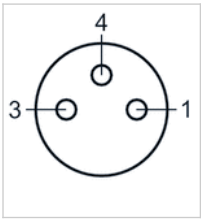

(1) BN=brown(3) BU=blue(4) BK=black

# Silencers, series SI1

- Sintered bronze



Working pressure min./max.	0 ... 10 bar
Ambient temperature min./max.	-25 ... 80 °C
Medium	Compressed air
Sound pressure level	See table below
Weight	See table below
Comment	Flow characteristic curves can be found under "Diagrams".

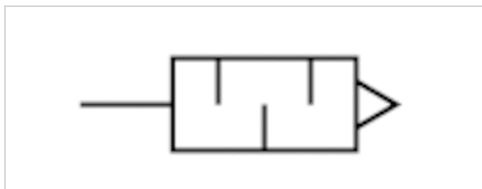

## Technical data

Part No.	Compressed air connection	Sound pressure level	Flow	Delivery unit	Weight
			Qn		
1827000006	M5	72 dB	398 l/min	10 piece	0,004 kg
1827000000	G 1/8	75 dB	1623 l/min	10 piece	0,01 kg
1827000001	G 1/4	79 dB	3390 l/min	10 piece	0,02 kg

Weight per piece

Nominal flow Qn at p1 = 6 bar (absolute) freely discharged. Sound pressure level measured at 6 bar against atmosphere at 1 m distance.

## Technical information

Material	
Silencers	Sintered bronze
Thread	Brass

## Dimensions

### Dimensions

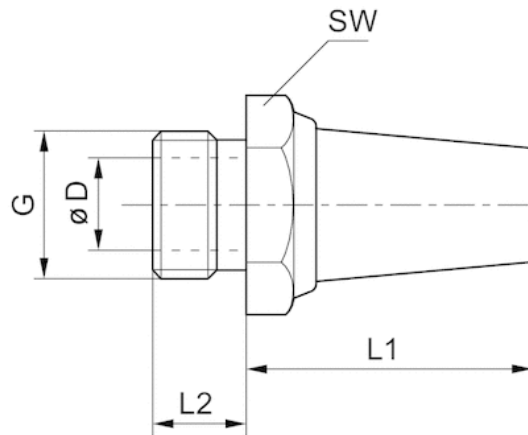

## Dimensions

Part No.	Port G	SW	Ø D	L1	L2
1827000006	M5	7	2.5	15	5
1827000000	G 1/8	13	6	18	6
1827000001	G 1/4	17	8.5	25	8

### Flow diagram 1827000005

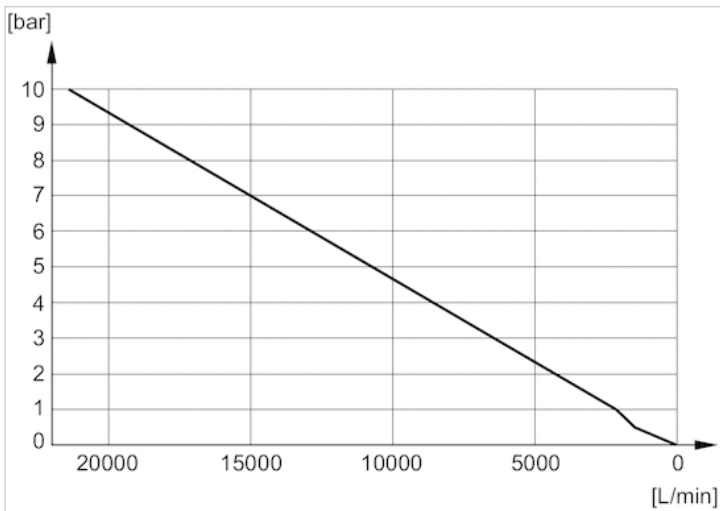

## Diagrams

Flow diagram 1827000006

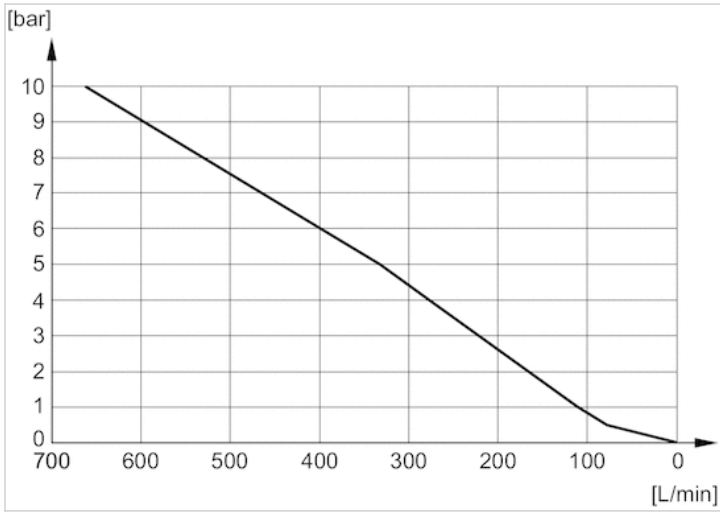

Flow diagram 1827000003

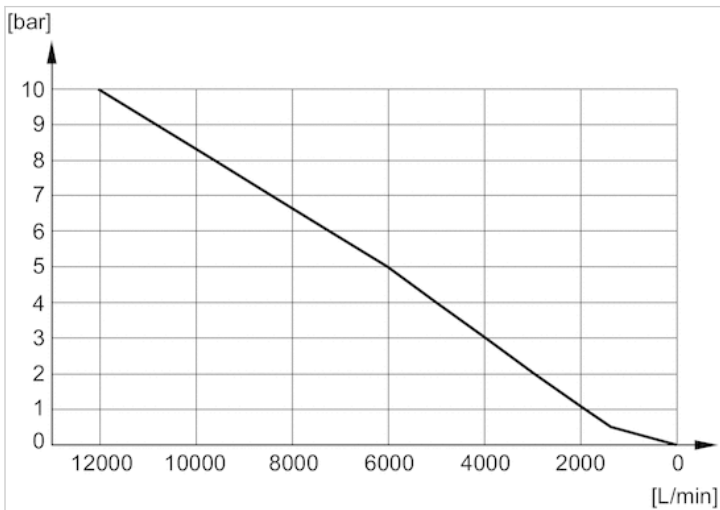

Flow diagram 1827000004

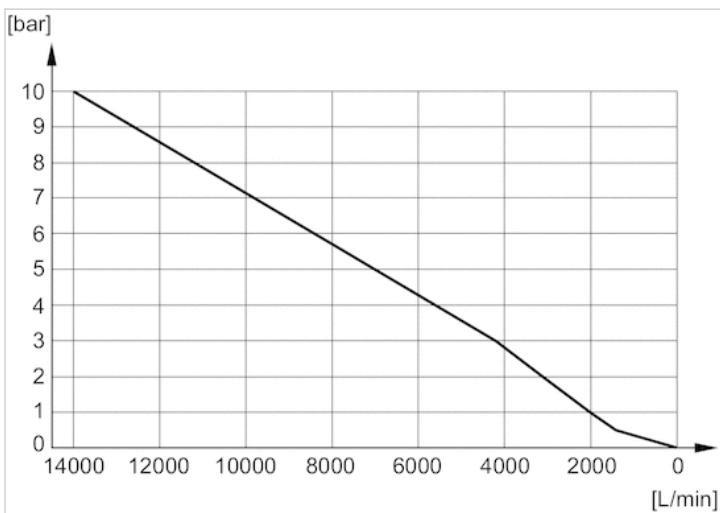

Flow diagram 5324001110

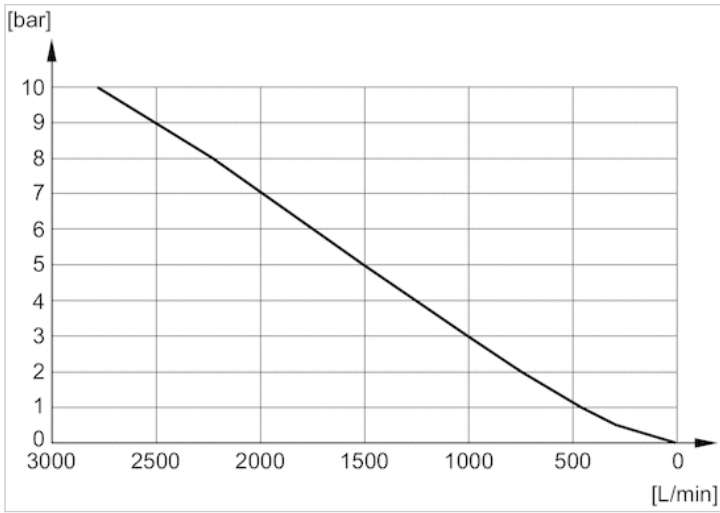

Flow diagram 5324001170

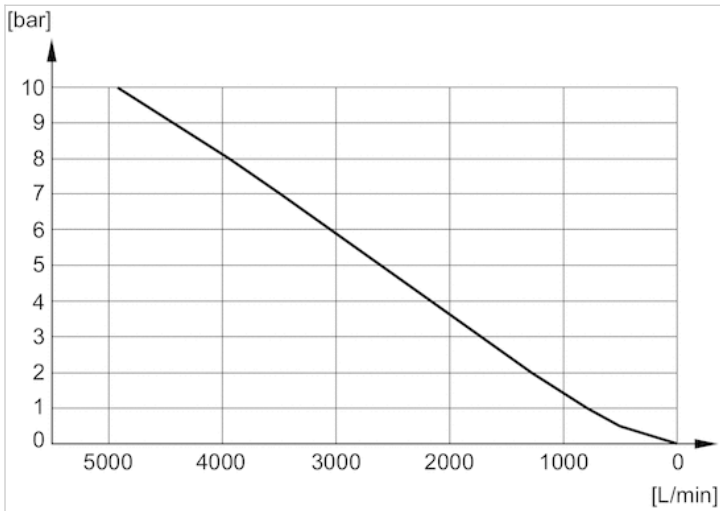

Flow diagram 5324001120

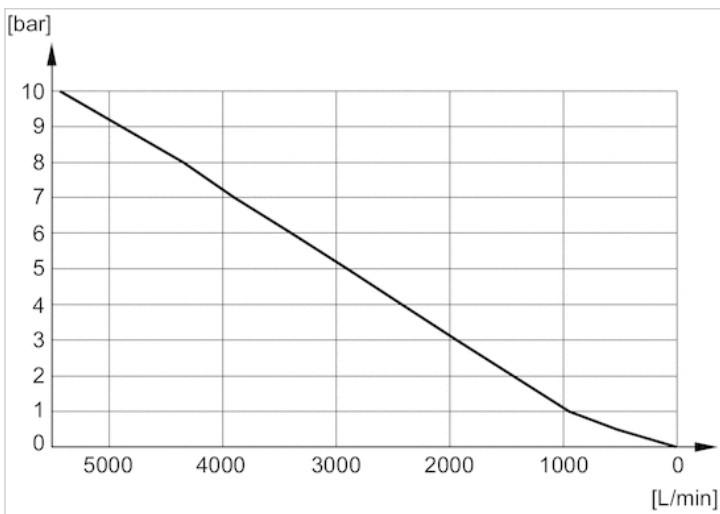

Flow diagram 5324001140

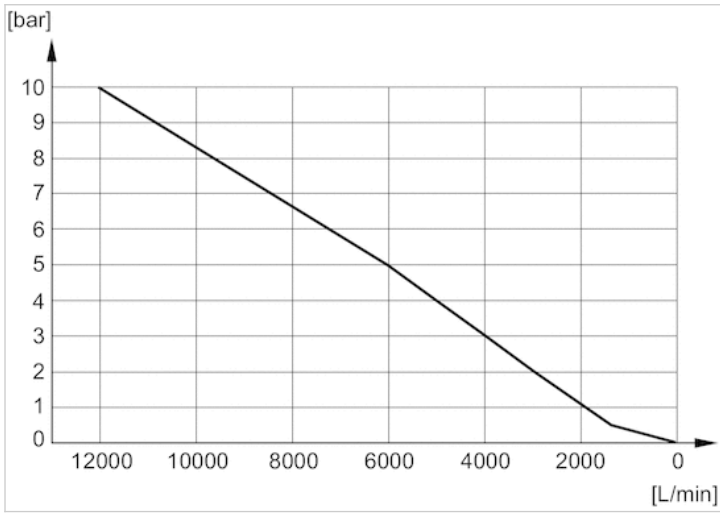

Flow diagram 1827000000

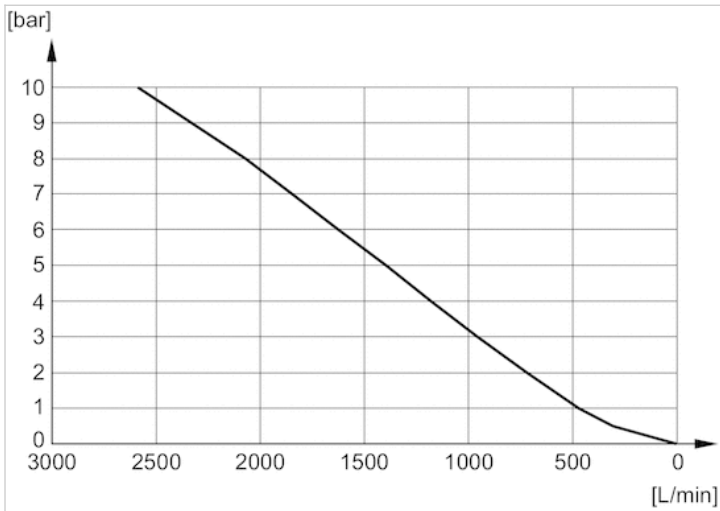

Flow diagram R412004817

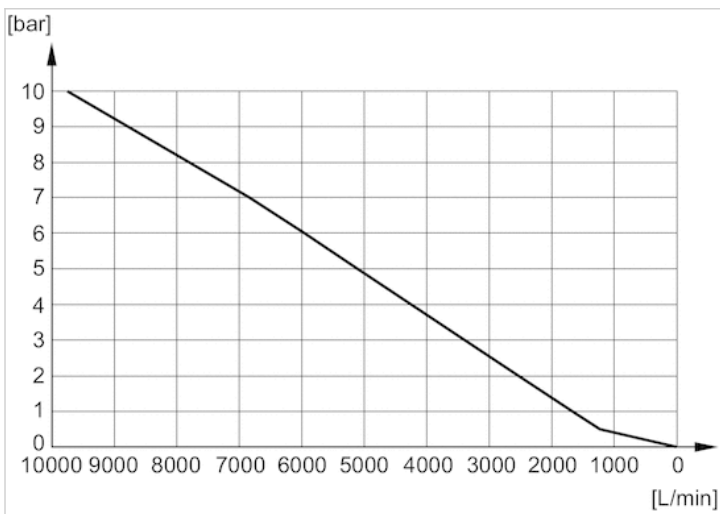

Flow diagram 1827000001

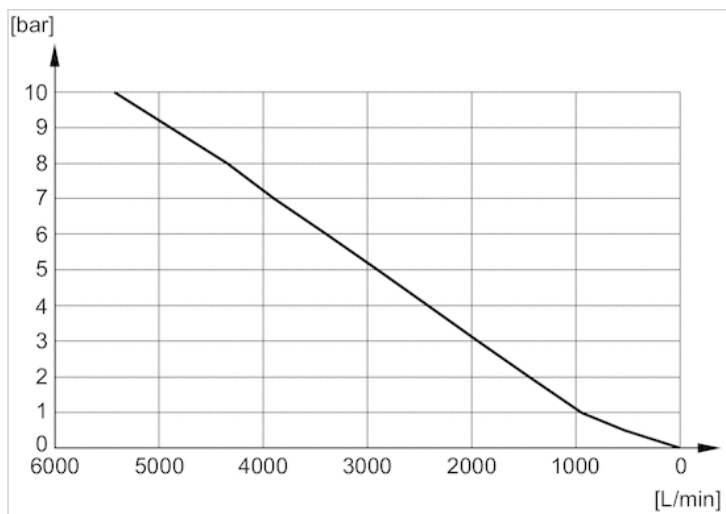

Flow diagram 1827000002

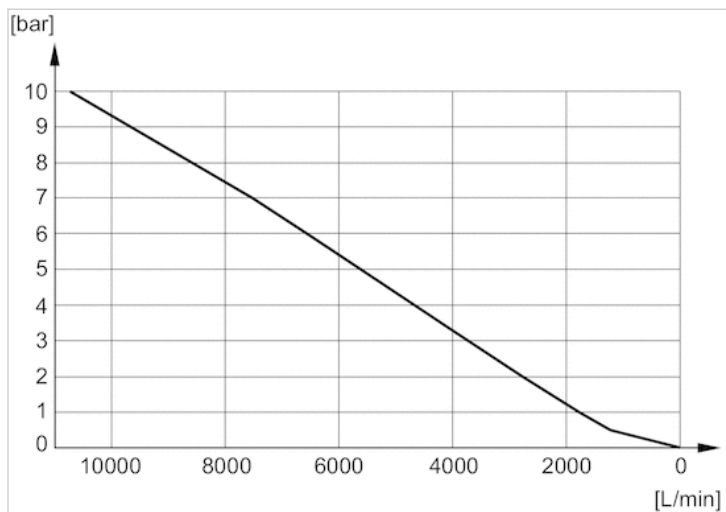

# Silencers, series SI1

- Sintered bronze



Working pressure min./max.

0 ... 10 bar

Ambient temperature min./max.

-25 ... 80 °C

Medium

Compressed air

Sound pressure level

See table below

Weight

See table below

Comment

Flow characteristic curves can be found under "Diagrams".

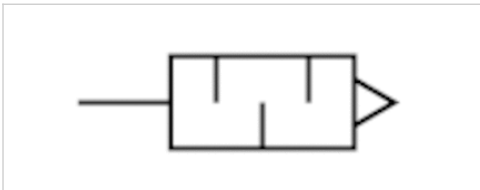

## Technical data

Part No.	Compressed air connection	Sound pressure level	Flow	Delivery unit	Weight
			Qn		
1827000032	M5	79 dB	252 l/min	10 piece	0,005 kg
1827000031	G 1/8	85 dB	700 l/min	10 piece	0,001 kg
1827000033	G 1/4	88 dB	1116 l/min	10 piece	0,01 kg

Weight per piece

Nominal flow Qn at p1 = 6 bar (absolute) freely discharged. Sound pressure level measured at 6 bar against atmosphere at 1 m distance.

## Technical information

Material	
Silencers	Sintered bronze
Thread	Brass

## Dimensions

### Dimensions

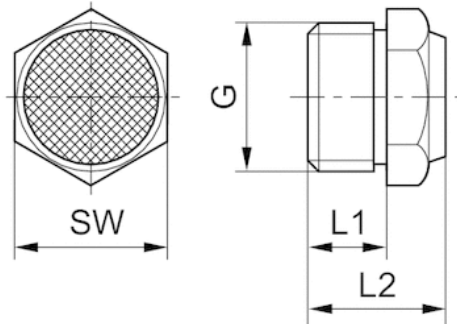

## Dimensions

Part No.	Port G	L1	L2	SW
1827000032	M5	5	10.3	7
1827000031	G 1/8	6	11.5	13
1827000033	G 1/4	8	13.5	17

Sound pressure level measured at 6 bar at 1 m distance

### Flow diagram 8145001000

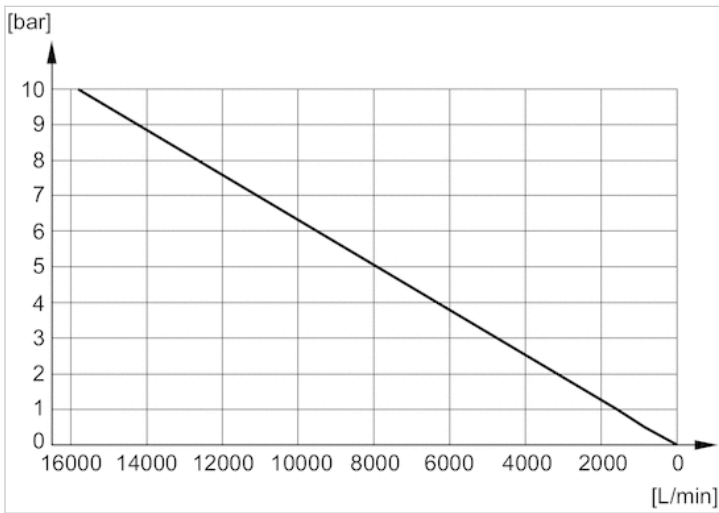

## Diagrams

Flow diagram 1827000032

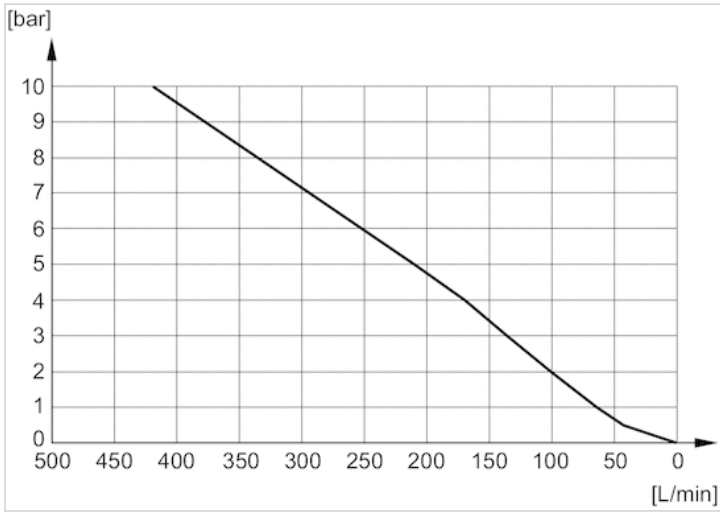

Flow diagram 1827000031

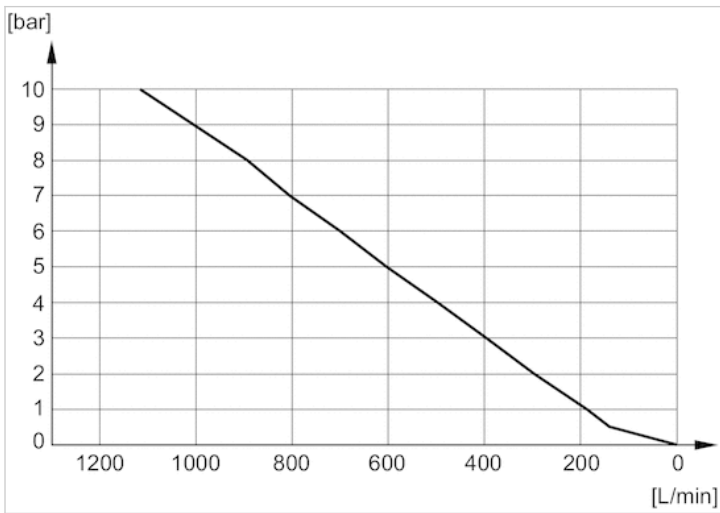

Flow diagram 1827000033

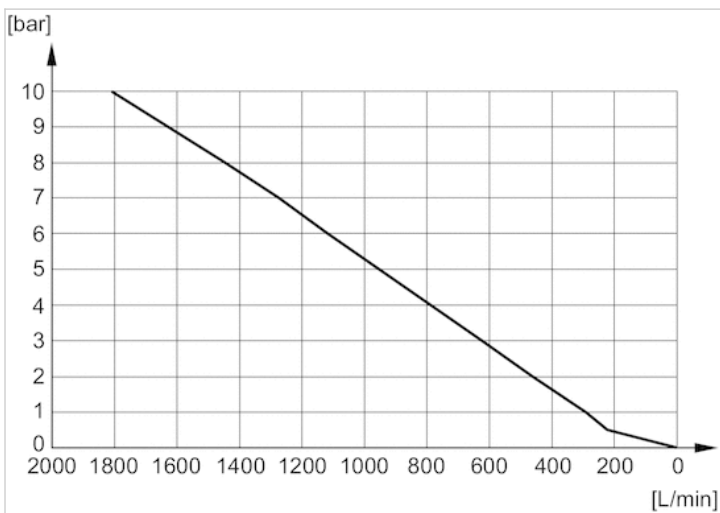

Flow diagram 1827000034

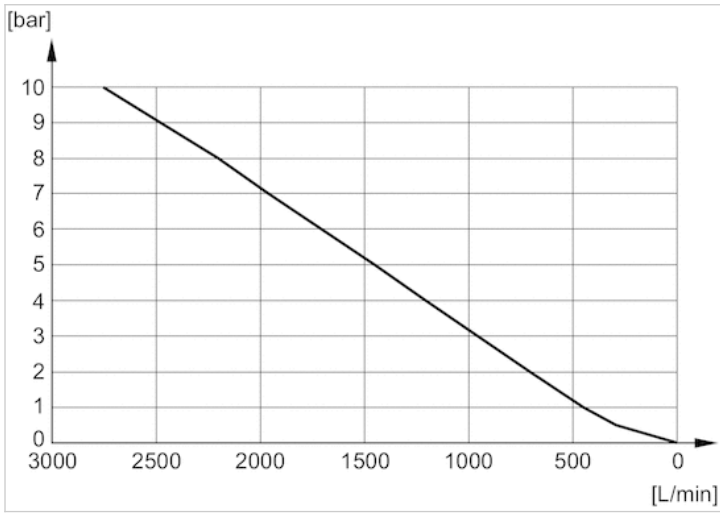

Flow diagram 1827000035

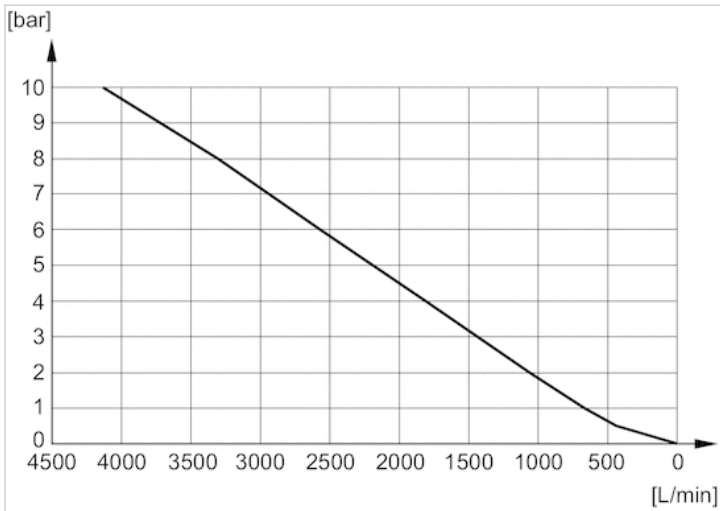

Flow diagram 8145003400

