

Actuator

MD66

MD66 is a quiet and powerful actuator up to 6000N thrust, designed for use in home care and medical bed. The control box MD6C, which can be perfectly attached and integrated to MD66 are available for customers to choose.



Features and Options

Main applications: Home care, medical

Standard features:

- Input voltage: 24V DC
- Max. load: 6000N (push) / 4000N (pull)
- Typical speed at no load: 16.6 mm/sec
- Typical speed at full load: 2.9 mm/sec (6000N load)
- Stroke: 50 ~ 300 mm
- Noise level: ≤ 50 dB
- IP Protection level: IPX5 (static (non-action))
- Color: Light gray RAL 7035
- Preset limit switches
- Duty cycle: 10%, max. 2 min. continuous operation in 20 min.
- Ambient operation temperature: +5°C ~ +40°C
- Certified: CE Marking, EN 60601-1-2, IEC 60601-1

Options:

- Positioning signal feedback with Hall effect sensor x 1
- Positioning signal feedback with Hall effect sensor x 2
- Mechanical push only extension tube
- Safety nut (in push direction)
- Mechanical brake (can't go with AG motor and spindle option)

Performance Data

Model No.	Push Max. (N)	Pull Max. (N)	*Self-locking ability (N)	**Typical Speed (mm/s)		**Typical Current (A) @ 24V	
				No load	Full load	No load	Full load
MD66-24-A4...	6000	4000	5000	4.2	2.9	0.6	2.7
MD66-24-A6...	4000	4000	2500	6.2	3.8	0.6	3.0
MD66-24-A8...	3000	3000	2000	8.3	5.0	0.6	2.7
MD66-24-AG...	1500	1500	700	16.6	12.2	0.6	2.8

Speed vs. Load

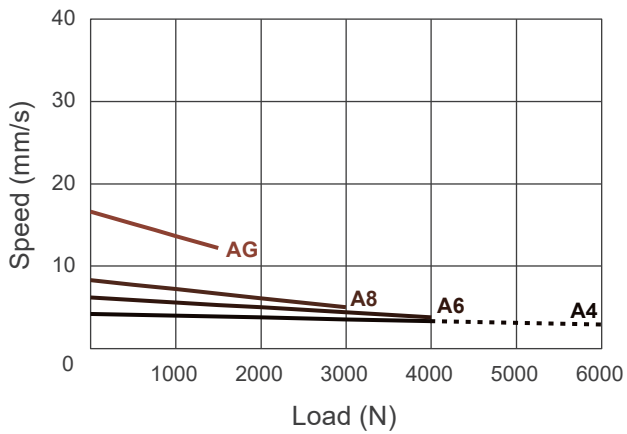

Current vs. Load

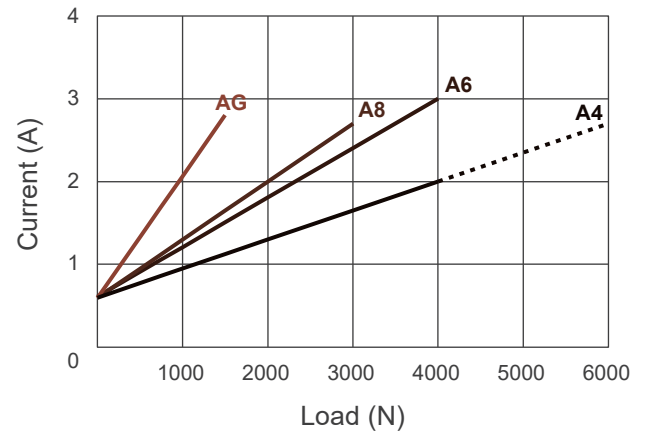

Push / Pull Load — Push Load - - -

Remarks:

- * Mechanical brake is option upon request, to enhance the braking ability conforming to maximum load.
- ** The typical speed or typical current means the average value neither upper limit nor lower limit. The performance curves are made with typical values.

Dimensions

● Retracted length (A)

Unit: mm

Front connector code	Retracted length (A)	Safety nut
3, 7	$A \geq S + 160\text{mm} (\pm 3\text{mm})$	Add 8mm to retracted length(A)
1, 6, 8	$A \geq S + 188\text{mm} (\pm 3\text{mm})$	

Available stroke (S) range = 50 ~ 300 mm

Extended length = S + A

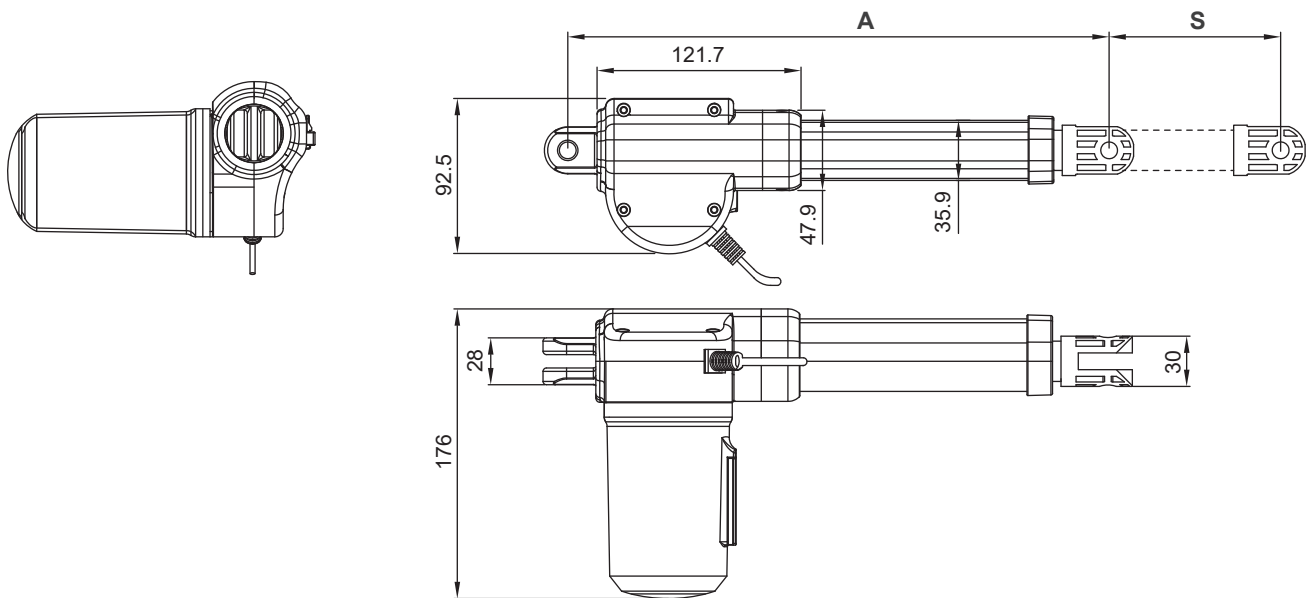

● **Front connector**

1: Plastic

3: Drilled hole

6: Enhanced plastic

7: Plastic bushing

8: Aluminum alloy clevis

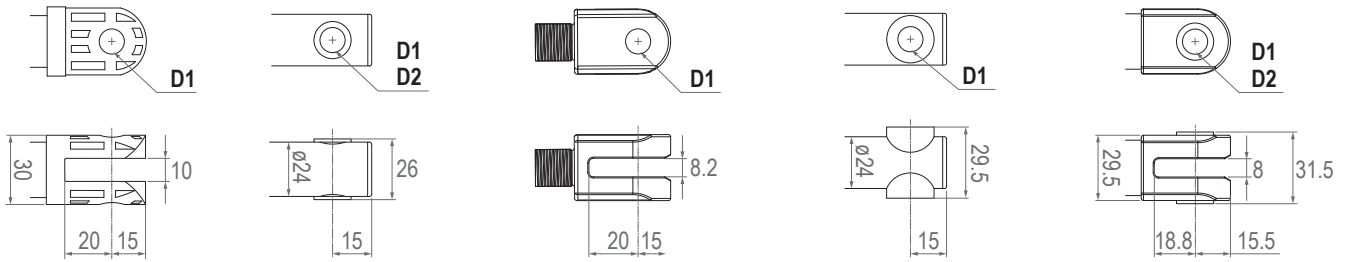

Front connector code	Diameter of pivot without bushing (D1)	Diameter of pivot with bushing (D2)
1	Ø8, Ø10, Ø12	N/A
3	Ø8, Ø10, Ø12, Ø14	Ø8, Ø10
6	Ø10	N/A
7	Ø10	N/A
8	Ø10, Ø12	Ø8, Ø10

● **Rear connector**

1: Aluminum alloy clevis

2: Zinc alloy clevis



Rear connector code	Diameter of pivot without bushing (D1)	Diameter of pivot with bushing (D2)
1	Ø10, Ø12	Ø8, Ø10
2	Ø10, Ø12	Ø8, Ø10

● **Pivot orientation of rear connectors**

0° (standard)

90°

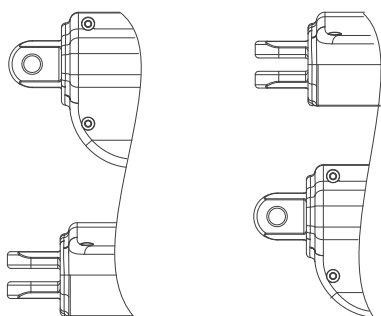

Compatibility

Product	Model	MD66 spec
Control box	CM41-M, CB5P-MA	- With Moteck LR-type minifit 6-pin plug
	*CB2P, CB4P, CB4P-HP, *MD6C, MD7C	- Without positioning sensor - With Moteck V-type or H-type 4-pin DIN plug
	CB4P-SY	- With dual Hall effect sensors for positioning - With Moteck V-type or H-type 6-pin DIN plug

Remarks:

* MD6C & CB2P control box can be attached to MD66 actuator.



MD66+MD6C



MD66+CB2P

Cable Plug

Motek LR-type minifit plug

- Positioning feedback with Hall effect sensors

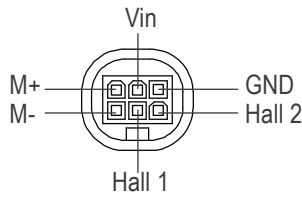

6-pin minifit plug



LR-type

Motek V-type or H-type DIN plug

- Without positioning feedback

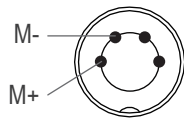

4-pin DIN plug



V-type

- Positioning feedback with Hall effect sensors

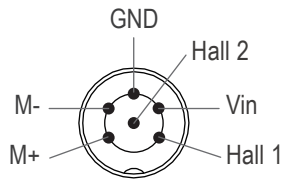

6-pin DIN plug



H-type

Note:

Connect M+ to "Vdc +" & M- to "Vdc -" of DC power to extend the actuator. Switch the polarity of DC input to retract it.

Cable with Flying Leads

Without positioning feedback

	Wire color	Definition	Comments
Power wires	White	DC power	Connect white wire to "Vdc +" & black wire to "Vdc -" of DC power to extend the actuator. Switch the polarity of DC input to retract it.
	Black		

With single Hall effect sensor for positioning

	Wire color	Definition	Comments										
Signal wires	Blue	DC power	Connect blue wire to "Vdc +" & Brown wire to "Vdc -" of DC power to extend the actuator. Switch the polarity of DC input to retract it.										
	Brown												
	Yellow	Vin	Voltage input range: 5 ~ 20V										
	Red	Hall output	High= Input - 1.2V ($\pm 0.6V$) Low= GND Hall signal data:  Hall effect sensor resolution: <table border="1" data-bbox="635 913 1455 1108"> <thead> <tr> <th>Model No.</th> <th>Resolution (pulses/mm)</th> </tr> </thead> <tbody> <tr> <td>MD66-XX-A4-XXX.XXX-CXX-HSX</td> <td>10.0</td> </tr> <tr> <td>MD66-XX-A6-XXX.XXX-CXX-HSX</td> <td>6.67</td> </tr> <tr> <td>MD66-XX-A8-XXX.XXX-CXX-HSX</td> <td>5.0</td> </tr> <tr> <td>MD66-XX-AG-XXX.XXX-CXX-HSX</td> <td>2.50</td> </tr> </tbody> </table>	Model No.	Resolution (pulses/mm)	MD66-XX-A4-XXX.XXX-CXX-HSX	10.0	MD66-XX-A6-XXX.XXX-CXX-HSX	6.67	MD66-XX-A8-XXX.XXX-CXX-HSX	5.0	MD66-XX-AG-XXX.XXX-CXX-HSX	2.50
	Model No.	Resolution (pulses/mm)											
MD66-XX-A4-XXX.XXX-CXX-HSX	10.0												
MD66-XX-A6-XXX.XXX-CXX-HSX	6.67												
MD66-XX-A8-XXX.XXX-CXX-HSX	5.0												
MD66-XX-AG-XXX.XXX-CXX-HSX	2.50												
Black	GND												

With dual Hall effect sensors for positioning

	Wire color	Definition	Comments										
Power wires	Blue	DC power	Connect blue wire to "Vdc +" & Brown wire to "Vdc -" of DC power to extend the actuator. Switch the polarity of DC input to retract it.										
	Brown												
Signal wires	Yellow	Vin	Voltage input range: 5 ~ 20V										
	Red	Hall 1 output	High= Input - 1.2V ($\pm 0.6V$) Low= GND Hall signal data:  Hall effect sensor resolution: <table border="1" data-bbox="635 1825 1455 2020"> <thead> <tr> <th>Model No.</th> <th>Resolution (pulses/mm)</th> </tr> </thead> <tbody> <tr> <td>MD66-XX-A4-XXX.XXX-CXX-HSX</td> <td>10.0</td> </tr> <tr> <td>MD66-XX-A6-XXX.XXX-CXX-HSX</td> <td>6.67</td> </tr> <tr> <td>MD66-XX-A8-XXX.XXX-CXX-HSX</td> <td>5.0</td> </tr> <tr> <td>MD66-XX-AG-XXX.XXX-CXX-HSX</td> <td>2.50</td> </tr> </tbody> </table>	Model No.	Resolution (pulses/mm)	MD66-XX-A4-XXX.XXX-CXX-HSX	10.0	MD66-XX-A6-XXX.XXX-CXX-HSX	6.67	MD66-XX-A8-XXX.XXX-CXX-HSX	5.0	MD66-XX-AG-XXX.XXX-CXX-HSX	2.50
	Model No.	Resolution (pulses/mm)											
	MD66-XX-A4-XXX.XXX-CXX-HSX	10.0											
MD66-XX-A6-XXX.XXX-CXX-HSX	6.67												
MD66-XX-A8-XXX.XXX-CXX-HSX	5.0												
MD66-XX-AG-XXX.XXX-CXX-HSX	2.50												
Green	Hall 2 output												
Black	GND												

Ordering Key

MD66- 24 - A8 - 538 - 588 - C 8 2 - HS4 - 0	
Input voltage	24: 24V DC
Motor and Spindle type	A4: 2500rpm / 4mm pitch A6: 2500rpm / 6mm pitch A8: 2500rpm / 8mm pitch AG: 2500rpm / 16mm pitch (Refer to Performance Data)
Retracted length	XXX (Refer to Dimensions)
Extended length	XXX (Refer to Dimensions)
Front connector	1: Plastic 3: Drilled hole 6: Enhanced plastic 7: Plastic bushing 8: Aluminum alloy clevis (Refer to Dimensions)
Rear connector	1: Aluminum alloy clevis 2: Zinc alloy clevis (Refer to Dimensions)
Positioning feedback	Blank: Without positioning feedback HS3: Hall effect sensor x 1 HS4: Hall effect sensor x 2
Option (multiple choice is allowed)	Blank: None SN: Safety nut (add 8mm to retracted length) PO: Push only BK: Mechanical brake (can't go with AG motor and spindle option)
Cable length	0: 300mm straight 3: 1000mm straight A: 450mm with 300mm coiled

Terms of Use

The user is responsible for application suitability of Moteck products. As ongoing improvement process continues, products listed on the Moteck website are subject to change without prior notice. Moteck reserves the right to terminate the sales or remove any product displayed on the website, or listed in its catalogues.